

# PD6820 Explosion-Proof Loop-Powered Rate/Totalizer

## Data Sheet



- Fully-Approved Explosion-Proof Loop-Powered Rate/Totalizer
- 4-20 mA Input with  $\pm 0.03\%$  Accuracy
- 3.0 Volt Drop (6.0 Volt Drop with Backlight)
- Easy Field Scaling in Engineering Units without Applying an Input
- 0.7" (17.8 mm) 5 Digits Main Display for Rate
- 0.4" (10.2 mm) 7 Alphanumeric Characters Secondary Display for Total, Tag, or Units
- Simultaneous 5-Digit Rate and 7-Digit Total Display
- Rate in Units per Second, Minute, Hour, or Day
- Display Open Channel Flow with Programmable Exponent Feature
- Open Collector Pulse or Alarm Output
- Display Mountable at 0°, 90°, 180°, & 270°
- SafeTouch Through-Glass Button Programming
- HART® Protocol Transparent
- Loop or External DC-Powered Backlight Standard
- Operating Temperature Range: -40 to 75°C (-40 to 167°F)
- Installation Temperature Range: -55 to 75°C (-67 to 167°F)
- CSA Certified as Explosion-Proof / Dust-Ignition-Proof / Flame-Proof
- ATEX and IECEx Certified as Explosion-Proof
- Conformal Coated PCBs for Dust and Humidity Protection
- Password Protection for Programming Only
- 32-Point Linearization, Square Root Extraction and Programmable Exponent Function
- Wide Viewing Angle
- Built-In Flange for Wall or Pipe Mounting
- Explosion-Proof, IP68, NEMA 4X Die-Cast Aluminum & Stainless Steel Enclosures
- Two 3/4" NPT or M20 Conduit Openings
- 2" U-Bolt Kit Available
- 3-Year Warranty

**FLUIDPRO**  
Dosing Systems

[www.fluidprodosingystems.com.au](http://www.fluidprodosingystems.com.au)

QLD 07 3071 7415 NSW 02 8069 2664 VIC 03 9021 6624



OVERVIEW



Rate/Totalizer Displays



Easy to Setup



KEY FEATURES

The PD6820 explosion-proof loop-powered rate/totalizer brings modern design, easy readability, and enhanced functionality to hazardous areas around the world. Competitors have lost sight of the fact that the primary thing customers want to do with meters such as these is to look at them. Customers want a meter that looks nice so they can be proud to install it in their facility. They want a meter with a display that provides the important information about their process, can be seen under varied lighting conditions, from wide angles, and from a distance. The PD6820 delivers all these and more.

Informative & Easy to Read Display

The high contrast, backlight LCD display is easy to read from far away and under various lighting conditions. The main display is 0.7" high and shows 5 digits of flow rate. The secondary display is 0.4" high and shows either flow total or a tag with 7 alphanumeric characters. And best of all, the display is mounted right up against the glass so it can be seen from a wide viewing angle.

Wide Viewing Angle

The window and display module have been optimized to provide a wide viewing angle of approximately ±40°; nearly twice that of the competition.



Through-Glass SafeTouch Buttons

The PD6820 is equipped with four sensors that operate as through-glass buttons so that it can be programmed and operated without removing the cover (and exposing the electronics) in a hazardous area. These buttons can be disabled for security by selecting the LOCK setting on the switch located on the connector board in the base of the enclosure. To actuate a button, press one finger to the glass directly over the marked button area.

Modern, Sleek and Practical Enclosure

The first thing customers notice about a product is its enclosure and the ProtEX-Pro really shines here. The PD6820 is available in aluminum and stainless steel with two ¾" or M20 conduit connections. The built-in mounting flange makes for convenient wall or pipe mounting and there is even a slot on the back of the enclosure for centering on the pipe.

Environmentally Tough

ProtEX Series meters not only look great with their modern, smooth die cast aluminum and stainless steel enclosures, but they can be installed virtually anywhere. The NEMA 4X / IP68 enclosure provides serious protection from the elements, high impact, corrosion and electrical interference. The ProtEX-Pro PD6820 will operate over a temperature range of -40 to 75°C (-40 to 167°F). Below -40°C, the display will cease functioning, however, the instrument is approved to be installed in locations where the temperature goes down to -55°C.

## INSTALLATION

### Perfect & Secure Fit Every Time

The internal cast rails ensure the ProtEX assemblies together perfectly, quickly and securely; and everything lines up for optimal viewing every time. There are no standoffs to worry about breaking or getting out of alignment. Two spring-loaded, self-retaining, thumbscrews make the assembly a snap.

### Installation Flexibility

The PD6820's rotatable display/meter module along with two available conduit connections provide for numerous installation options. The display can be rotated in 90° increments. Rotate it 90° for horizontal mounting. Wiring can then be routed to either the top conduit connection, or from below to the opposite conduit connection. Use both conduit connections for through-wiring in any plane.



### Easy Wiring & Service

Unscrew the two captured thumb screws and unplug a connecting cable and the display/meter module is simply and completely removed. A heavy duty terminal block is then easily accessed and wired. It is clearly marked to prevent wiring errors. The display/meter module can be removed *without breaking the loop*. As such, it can be serviced without the need to uninstall the entire product.

## TOTALIZER CAPABILITIES

### Totalizer Pulse Output

The totalizer pulse output function requires use of the open collector output. It will output a pulse at a user adjustable pulse rate, and can be scaled with a K-factor of between 0.0001 and 99999. Example: For 1 pulse every 500 gallons, set the K-factor to 500. This output can be sent to a PLC or counter.

### Totalizer Conversion Factor

Total Conversion Factor is used to convert to a different unit of measure for the total display. For example, to display rate in gallons and total in liters, enter a conversion factor of 3.7854. When rate and total units are the same, the Conversion Factor should be 1.0000.

### Total Reset

The total can be reset either manually via the front panel RESET button or external contact; or automatically using a programmed setpoint and delay time. Total reset can also be disabled.

## INPUT SIGNAL CONDITIONING

### Live Input Calibration

In lieu of meter scaling, the meter can be calibrated with a precision signal source. While applying a precision signal, the relative scale value is entered via the front panel. This is done at any two points along the scale. Using this method, the operator can set a "best fit straight line" for non-linear input spans.

### Multi-Point Linearizer

Up to 32 linearization points can be selected under the Linear function. The multi-point linearization can be used to linearize the display for non-linear signals such as those from level transmitters used to measure volume in odd-shaped tanks or to convert level to flow using weirs and flumes that require a complex exponent. These points are established via direct entry (SCLR) or with an external calibration signal (CLR).

### Square Root Extraction

The square root extraction function displays flow rate by extracting the square root from a differential pressure transmitter signal. The user selectable low-flow cutoff feature gives a reading of zero when the flow rate drops below a user selectable value.

### Programmable Exponent

The programmable exponent function is used to linearize the level signal in open channel flow applications using weirs and flumes and display flow rate & total, units of measure, or toggle between total and units of measure.

## ADDITIONAL FEATURES

### Password Protection

A 5-digit password prevents unauthorized changes to the programmed parameter settings. The lock symbol is displayed to show that settings are protected. If the meter is password protected, the meter will display the message LOCKED when the Menu button is pressed.

### Alarm Indication

The PD6820 can be configured to have a high or low rate alarm indicator, or a total alarm trip point indicator. The OC output is available for use as an alarm output. When in alarm mode, the display will flash, and a HI or LO symbol is displayed. The alarm has an adjustable deadband and is acknowledged by pressing the ENTER button.

**ACCESSORIES**

**PDA6846-SS 2" U-Bolt Kit**



The PDA6846-SS stainless steel U-Bolt Kit provides a convenient way to mount the meter to 1.5" or 2" pipes.

Model	Description
<a href="#">PDA6846-SS</a>	2" Stainless Steel U-Bolt Kit with One U-Bolt

**PDA-SSTAG Stainless Steel Tag**



The PDA-SSTAG is a laser etched stainless steel tag that can be customized with three lines of text. Each tag comes with a stainless steel wire and lead seal for easy mounting wherever you need.

Model	Description
<a href="#">PDA-SSTAG</a>	Stainless Steel Tag

**24 VDC Transmitter Power Supply**



The PDA1024-01 24 VDC power supply can be used for a variety of functions like powering 4-20 mA transmitters. It can be mounted on a [PDA1002](#) DIN rail.

Model	Description
<a href="#">PDA1024-01</a>	24 VDC Transmitter Power Supply
<a href="#">PDA1002</a>	6" DIN Rail Mounting Kit

**PDA1024-01 Specifications**

<b>Input Voltage</b>	85-264 VAC; 120-370 VDC
<b>Output Voltage</b>	21.6-29 VDC; 1.5 A rated current.
<b>Input Frequency</b>	47-63 Hz
<b>AC Current</b>	115 VAC: 0.88 A; 230 VAC: 0.48 A
<b>Connections</b>	Screw terminals
<b>Overload Protection</b>	105-160% rated output power. Constant current limiting, recovers automatically after fault condition is removed
<b>Operating Temperature</b>	-30 to 60°C (-22 to 140°F)
<b>Vibration</b>	10-500 Hz, 2G 10 min./1 cycle, period for 60 min. each along X, Y, Z axes
<b>Safety Standards</b>	UL 508 Listed and UL Recognized Component
<b>Dimensions</b>	1.40" x 3.50" x 2.10" (35 mm x 90 mm x 54.5 mm) (W x H x D)
<b>Warranty</b>	1 year parts & labor

**⚠ WARNING**

- PDA1024-01 does not carry hazardous area approvals and is thus not suitable for location in hazardous areas. The use of additional protective devices may allow it to be installed in a safe area and connected to a device in a hazardous area. User should consult a professional engineer to determine suitability of these products for their specific application.



**USEFUL TOOLS**

**PD9501 Multi-Function Calibrator**



This PD9501 Multi-Function Calibrator has a variety of signal measurement and output functions, including voltage, current, thermocouple, and RTD.

Model	Description
<a href="#">PD9501</a>	Multi-Function Calibrator

**PD9502 Low-Cost Signal Generator**



The PD9502 is a low-cost, compact, simple to use 4-20 mA or 0-10 VDC signal generator. It can easily be set for 0-20 mA, 4-20 mA, 0-10 V or 2-10 V ranges. Signal adjustment is made with a one-turn knob. A 15-27 VDC wall plug is provided with the instrument. Optional USB power bank is available.

Model	Description
<a href="#">PD9502</a>	Low Cost Signal Generator
<a href="#">PDA1001</a>	USB Power Bank

**DIMENSIONS**

Units: Inches (mm)

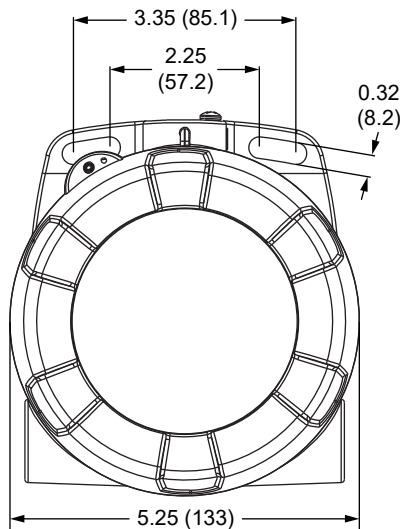

Front View

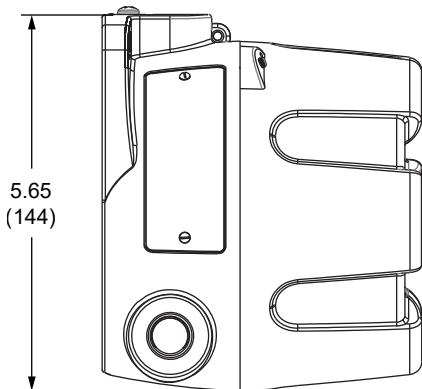

Side View

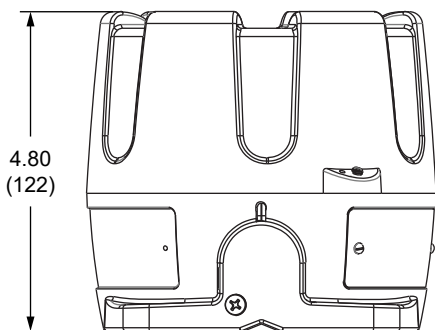

Top View

**CONNECTIONS**

**Connectors Labeling**

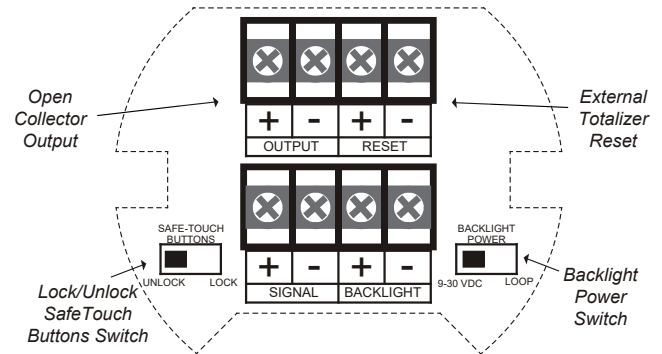

**WIRING DIAGRAMS**

For existing applications, one of the great benefits of loop-powered meters is that they get their power directly from the 4-20 mA loop and thus require no additional wiring. All a user has to do is break the existing loop and wire in the meter.

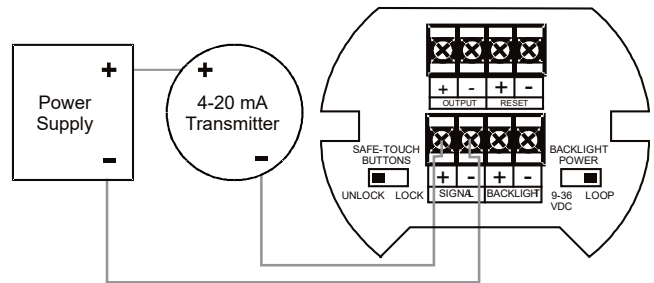

4-20 mA Input Connection without Backlight

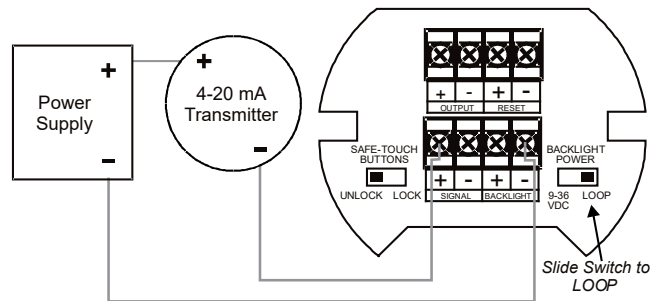

4-20 mA Input Connection with Backlight

See LIM6820 manual for complete wiring instructions



Download free 3-D CAD files of these instruments to simplify your drawings!

[predig.com/documentation-cad](http://predig.com/documentation-cad)

## SPECIFICATIONS

Except where noted all specifications apply to operation at +25°C.

### General

<b>Display</b>	Five digits (-9999 to 99999)	0.70" (17.8 mm) high, 7-segment, automatic lead zero blanking			
	Seven characters	0.40" (10.2 mm) high, 14-segment			
	Symbols	High & Low Alarm, Password Lock			
<b>Display Orientation</b>	Display may be mounted at 90° increments up to 270° from default orientation.				
<b>Display Assignment</b>	Upper display is assigned to rate and lower display may be assigned to total, tag name/ engineering units, or to alternate between them.				
<b>Display Update Rate</b>	Ambient > -25°C: 2 Updates/Second Ambient < -25°C: 1 Update/5 Seconds				
<b>Backlight</b>	White; Loop-powered or externally powered. Backlight can be enabled or disabled via alternative wiring of terminal block. Loop-powered backlight brightness will increase as the input signal current increases. Externally powered backlight has consistent brightness.				
<b>Externally Powered Backlight</b>	<i>Voltage Range: 9-36 VDC</i>				
	<b>Supply V</b>	9 VDC	12 VDC	24 VDC	36 VDC
	<b>Max Pwr</b>	0.2 W	0.25 W	0.5 W	0.75 W
<b>Display Overrange</b>	Display flashes 99999				
<b>Display Underrange</b>	Display flashes -9999				
<b>Programming Method</b>	Four SafeTouch through-glass buttons when cover is installed. Four internal pushbuttons when cover is removed.				
<b>Noise Filter</b>	Programmable $LQ$ , $n$ , $Ed$ , $H I$ , or $OFF$				
<b>Recalibration</b>	Recalibration is recommended at least every 12 months.				
<b>Max/Min Display</b>	Max/Min readings reached by the process are stored until reset by the user or until power to the meter is turned off.				
<b>Advanced Function</b>	Linear, square root, or programmable exponent				
<b>Password</b>	Programmable password restricts modification of programmed settings.				
<b>Non-Volatile Memory</b>	All programmed settings are stored in non volatile memory for a minimum of ten years if power is lost.				
<b>Normal Mode Rejection</b>	64 dB at 50/60 Hz				
<b>Environmental</b>	Operating temperature range: -40 to 75°C (-40 to 167°F)				
	Storage temperature range: -55 to 75°C (-67 to 167°F)				
	Installation temperature range: -55 to 75°C (-67 to 167°F)				
	(The display ceases to function below -40°C)				
	Relative humidity: 0 to 90% non-condensing Printed circuit boards are conformally coated				
<b>Connections</b>	Screw terminals accept 12 to 22 AWG wire				
<b>Mounting</b>	May be mounted directly to conduit. Built-in flange for wall mounting or NPS 1½" to 2½" or DN 40 to 65 mm pipe mounting.				

<b>Overall Dimensions</b>	5.65" x 5.25" x 4.86" (W x H x D) (144 mm x 133 mm x 124 mm)
<b>Weight</b>	Aluminum: 4.8 lbs (2.18 kg) Stainless Steel: 8.7 lbs (4.3 kg)
<b>Warranty</b>	3 years parts and labor. See Warranty Information and Terms & Conditions on <a href="http://www.predig.com">www.predig.com</a> for complete details.

### Input

<b>Input</b>	4-20 mA	
<b>Accuracy</b>	±0.03% of calibrated span ±1 count, square root & programmable exponent accuracy range: 10-100% of calibrated span.	
<b>Maximum Voltage Drop &amp; Equivalent Resistance</b>	<b>Without Backlight</b>	<b>With Loop Powered Backlight</b>
	3.0 VDC @ 20 mA	6 VDC @ 20 mA
	150 Ω @ 20 mA	300 Ω @ 20 mA
<b>Multi-Point Linearization</b>	2 to 32 points	
<b>Signal Input Conditioning</b>	Linear, square root, programmable exponent	
<b>Programmable Exponent</b>	User selectable from 1.0001 to 2.9999 for open channel flow.	
<b>Low Flow Cutoff</b>	0-99999 (0 disables cutoff function) Point below at which display always shows zero.	
<b>Decimal Point</b>	User selectable decimal point	
<b>Minimum Span</b>	Input 1 & Input 2: 0.10 mA	
<b>Calibration Range</b>	An Error message will appear if input 1 and input 2 signals are too close together.	
	<b>Input Range</b>	<b>Minimum Span Input 1 &amp; Input 2</b>
	4-20 mA	0.10 mA
<b>Input Overload</b>	Over current protection to 2 A max	
<b>HART Transparency</b>	The meter does not interfere with existing HART communications; it displays the 4-20 mA primary variable and it allows the HART communications to pass through without interruption. The meter is not affected if a HART communicator is connected to the loop. The meter does not display secondary HART variables.	

**Open Collector Output**

<b>Rating</b>	Isolated open collector, sinking NPN 30 VDC @ 150 mA max.
<b>Alarm Output</b>	Assign to rate for high or low alarm trip point. Assign to total for total alarm trip point.
<b>Deadband</b>	0-100% FS, user selectable
<b>Acknowledge</b>	Front panel ACK button resets output and screen indication.
<b>Pulse Output Scaler (Count)</b>	The pulse output scaler (count) is programmable from 0.0001 to 99999. One pulse is generated for every total increment selected (e.g. A pulse scaler value of 100 will generate one pulse every time the total is incremented by 100 units). If the pulse output exceeds the programmed output frequency, pulses are accumulated as pending and are not lost. Pulses will continue to output until the buffer is emptied or the total is reset from the front panel.
<b>Pulse Output Frequency</b>	Programmable frequency: 2, 4, 8, 16, 32, 64, 128 Hz. Minimum pulse width: 3.9 ms @ 128 Hz Maximum pulse width: 250 ms @ 2 Hz Factory default pulse width: 31 ms @ 16 Hz

**Rate/Totalizer**

<b>Rate Display</b>	0 to 99,999 leading zero blanking
<b>Total Display</b>	0 to 9,999,999 leading zero blanking
<b>Total Decimal Point</b>	Up to six decimal places or none: d.dddddd, d.ddddd, d.dddd, d.ddd, d.dd, d.d, or ddddddd
<b>Lower Display Configuration</b>	Can be programmed to display total, tag name/ engineering units, or to alternate between them.
<b>Totalizer</b>	Calculates total based on rate, time base of second, minute, hour, or day, and field programmable multiplier; stored in non-volatile memory upon power loss.
<b>Totalizer Reset</b>	Via front panel SafeTouch button, time delay, external contact closure, or protected
<b>Total Conversion Factor</b>	0.000001 to 9,999,999
<b>Totalizer Rollover</b>	Display rolls over when display exceeds 9,999,999. Relay status reflects the displayed value.
<b>Total Reset Delay</b>	Programmable from 0 to 99,999 seconds



## Enclosure

<b>Material</b>	AL Models: ASTM A413 LM6 die-cast aluminum, copper-free, enamel coated SS Models: ASTM A743 CF8M investment-cast 316 stainless steel
<b>Gasket (O-Ring)</b>	Fluoroelastomer
<b>Rating</b>	NEMA 4X, IP68 Explosion-proof
<b>Color</b>	AL: Blue; SS: Silver
<b>Window</b>	Borosilicate glass
<b>Conduits</b>	PD6820-0K1: Two 3/4" NPT PD6820-0K1-M20: Two M20 PD6820-0K1-SS: Two 3/4" NPT PD6820-0K1-SS-M20: Two M20
<b>Flange</b>	Built-in flange for wall and pipe mounting
<b>Tamper-Proof Seal</b>	Cover may be secured with tamper-proof seal
<b>ATEX &amp; IECEx</b>	Flame-proof protection ⊕ II 2 G D Ex db IIC Gb Ex tb IIIC Db IP66/IP68 Tamb: -55°C to +85°C Certificate Number: Sira 19ATEX1252U Certificate Number: IECEx SIR 19.0075U
<b>CSA</b>	Class I, Division 1, Groups A, B, C, D Class II, Division 1, Group E, F, G Class III Ex db IIC Gb; Ex tb IIIC Db Class I, Zone 1, AEx db IIC Gb Zone 21, AEx tb IIIC Db IP66/IP68/TYP E 4X Tamb: -55°C to +85°C Certificate Number: CSA 19.80011200U
<b>UL</b>	Class I, Division 1, Groups A, B, C, D Class II, Division 1, Groups E, F, G Class III Class I, Zone 1, AEx db IIC Gb Zone 21, AEx tb IIIC Ex db IIC Gb; Ex tb IIIC Db IP66/IP68/TYP E 4X Tamb: -55°C to +85°C Certificate Number: E518920

**Note:** The above approvals are for the enclosure only. See next column for approval on the entire instrument.

## General Compliance Information

### Electromagnetic Compatibility

- EMC Emissions**
- CFR 47 FCC Part 15 Subpart B Class A emissions requirements (USA)
  - ICES-003 Information Technology emissions requirements (Canada)
  - AS/NZS CISPR 11 Group 1 Class A ISM emissions requirements (Australia/New Zealand)
  - EN 55011 Group 1 Class A ISM emissions requirements (EU)
  - EN 61000-6-4 Emissions requirements for Heavy Industrial Environments - Generic

**EMC Emissions and Immunity** EN 61326-1 EMC requirements for Electrical equipment for measurement, control, and laboratory use – industrial use

### Product Ratings and Approvals

<b>CSA</b>	Explosion-proof for use in: Class I, Division 1, Groups B, C, D Class II, Division 1, Groups E, F, G Class III, Division 1, T6 Ex d IIC T6 Ta = -55°C to +75°C Enclosure: Type 4X & IP66/68 Certificate Number: CSA 11 2325749
<b>ATEX</b>	Explosion-proof for use in: ⊕ II 2 G D Ex db IIC T6 Gb Ex tb IIIC T85°C Db IP68 Ta = -55 to 75°C Certificate Number: Sira 10ATEX1116X
<b>IECEx</b>	Explosion-proof for use in: Ex db IIC T6 Gb Ex tb IIIC T85°C Db IP68 Ta = -55 to 75°C Certificate Number: IECEx SIR 10.0056X

## ORDERING INFORMATION

### PD6820-0K1

PD6820 Explosion-Proof RTA • Aluminum Enclosure	
Model	Description
PD6820-0K1	Explosion-Proof Loop-Powered Process Meter with Backlight and Two 3/4" Conduit Openings
PD6820-0K1-M20	Explosion-Proof Loop-Powered Process Meter with Backlight and Two M20 Conduit Openings

PD6820 Explosion-Proof RTA • Stainless Steel Enclosure	
Model	Description
PD6820-0K1-SS	Explosion-Proof Loop-Powered Process Meter with Backlight and Two 3/4" Conduit Openings
PD6820-0K1-SS-M20	Explosion-Proof Loop-Powered Process Meter with Backlight and Two M20 Conduit Openings

### Accessories

Model	Description
<a href="#">PDAPLUG50</a>	1/2" NPT 316 Stainless Steel Conduit Plug with Approvals
<a href="#">PDAPLUGM20</a>	M20 316 Stainless Steel Conduit Plug with Approvals
<a href="#">PDAADAPTER-50M-75F</a>	M-1/2" NPT to F-3/4" NPT Adapter with Approvals
<a href="#">PDAADAPTER-50M-M20F</a>	M-1/2" NPT to F-M20 Adapter with Approvals
<a href="#">PD9501</a>	Multi-Function Calibrator
<a href="#">PD9502</a>	Low-Cost Signal Generator
<a href="#">PDA1001</a>	USB Power Bank
<a href="#">PDA1002</a>	6" DIN Rail Mounting Kit
<a href="#">PDA1024-01</a>	24 VDC Power Supply for DIN Rail
<a href="#">PDA-SSTAG</a>	Stainless Steel Tag
<a href="#">PDA6846-SS</a>	2" Stainless Steel U-Bolt Kit with One U-Bolt

**Note:** Unless otherwise specified, the above accessories do not carry hazardous area approvals and are thus not suitable for location in hazardous areas.

#### WARNING

Cancer and Reproductive Harm - [www.P65Warnings.ca.gov](http://www.P65Warnings.ca.gov)

#### Disclaimer

The information contained in this document is subject to change without notice. Precision Digital Corporation makes no representations or warranties with respect to the contents hereof, and specifically disclaims any implied warranties of merchantability or fitness for a particular purpose.

©2023 Precision Digital Corporation. All rights reserved.

## PRECISION DIGITAL CORPORATION

233 South Street • Hopkinton MA 01748 USA  
 Tel (800) 343-1001 • (508) 655-7300  
[www.predig.com](http://www.predig.com)

LDS6820\_F 06/23

