

PD6938 ProtEX+ and VantageView+ Flow Rate/Totalizers

Data Sheet



ProtEX+
Aluminum Enclosure



ProtEX+
Stainless Steel Enclosure



VantageView+
Plastic Enclosure



- Fully-Approved Explosion-Proof & Intrinsically Safe Pulse Input Flow Rate/Totalizers (ProtEX+)
- Field-Mount Pulse Input Flow Rate/Totalizers (VantageView+)
- NPN Open Collector, PNP, TTL, Switch Contact, Sine Wave (Magnetic Pickup Coil), or Active Square Wave Inputs
- Top Display: Five 12-Segment Alphanumeric Characters, 0.7" (17.8 mm)
- Bottom Display: Eight 14-Segment Alphanumeric Characters, 0.4" (10.2 mm)
- Display Mountable at 0°, 90°, 180°, & 270° (No Tools Required)
- CapTouch Through-Glass Button Programming with Normal and Delayed Modes
- Red Backlight for Alarm Conditions, Enable and Disable Backlight from Menu
- 8-Digit Total & Grand Total Display, Up to 13 Digits Using Both Lines
- Display Rate & Total Simultaneously
- Bi-Directional Flow Detection Via Digital Input
- Non-Resettable Grand Total
- Display Previous Total and Previous Grand Total with Time-of-Day Reset Feature
- Reset Total / Grand Total with CapTouch Button, Digital Input, or Time-of-Day Feature
- Automatic or Manual Batch Control
- K-Factor Calibration or Scaling with Up to 32-Point Linearization
- Gate Function for Rate Display of Slow Pulse Rates
- (2) Open Collector Outputs Standard; Assignable to Pulse, Alarm, Timer, or Stopwatch
- (2) Optional Solid-State Relays; Assignable to Alarm, Sample, Timer, Batch Control, or Stopwatch
- Optional Isolated 4-20 mA Analog Output
- Free PC-Based MeterView XL USB Programming Software
- 9-30 VDC, Battery, or 4-20 mA Output Power Options
- Battery-Powered Momentary Backlight & Display Sleep and Off Modes to Extend Battery Life
- Modbus RTU RS-485 Communications Standard on DC & Battery Powered Models
- On-Board Data Logging of up to 2,032 Records and Modbus Accessible Data
- Password Protection for Settings, Total & Grand Total
- CSA Certified for Explosion-Proof / Dust-Ignition Proof / Flame-Proof
- ATEX and IECEx Certified as Intrinsically Safe and Explosion-Proof
- Operating Temp Range: -40 to 75°C (-40 to 167°F)
- Installation Temp Range: -55 to 75°C (-67 to 167°F)
- Conformal Coated PCBs for Dust & Humidity Protection
- Flange for Wall or Pipe Mounting; Loop for Stainless Steel Tag; Holes for Tamper-Proof Seal
- Explosion-Proof Aluminum & Stainless Steel Enclosures with 1", 3/4", or M20 Connections (ProtEX+)
- Plastic NEMA 4X, IP66 Enclosure with Three 3/4" NPT Threaded Conduit Openings (VantageView+)
- 3-Year Warranty

FLUIDPRO
Dosing Systems

www.fluidprodosingystems.com.au

QLD 07 3071 7415 NSW 02 8069 2664 VIC 03 9021 6624

**PRECISION
DIGITAL**



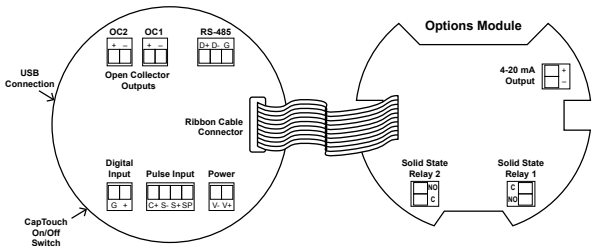

TABLE OF CONTENTS

OVERVIEW	3
DISPLAY FEATURES	5
CAPTOUCH THROUGH-WINDOW BUTTONS	9
OUTPUTS	10
BATCH CONTROL	11
TOTALIZER CAPABILITIES	14
ADVANCED FEATURES	15
DATA LOGGING	16
PHYSICAL FEATURES	17
POWER OPTIONS	20
OPERATIONAL FEATURES	21
METERVIEW XL PROGRAMMING SOFTWARE	23
ACCESSORIES	25
DIMENSIONS	27
CONNECTIONS	28
WIRING DIAGRAMS	34
SPECIFICATIONS	37
ORDERING INFORMATION	43

OVERVIEW

ProtEX+ Series

Front	Connections		
  <div style="display: flex; justify-content: space-around;"> <div style="text-align: center;"> <p>PD6938-##-AL Flow Rate/Totalizer Aluminum</p> </div> <div style="text-align: center;"> <p>PD6938-##-SS Flow Rate/Totalizer Stainless Steel</p> </div> </div>	 <p>Connections for DC Powered -D5M Option</p> <table border="0" style="width: 100%;"> <tr> <td style="vertical-align: top;"> <p>Standard</p> <ul style="list-style-type: none"> • (2) Open Collector Outputs Standard (150 mA max); Assignable to Pulse, Alarm, Timer, or Stopwatch • Digital Input for Remote Operation of a Single Task (Reset Total, etc.) </td> <td style="vertical-align: top;"> <p>Options</p> <ul style="list-style-type: none"> • (2) Loop-Powered Solid-State Relays; Assignable to Alarm, Batch Control, Timer, or Stopwatch • Isolated 4-20 mA Analog Output • Modbus RTU RS-485 Communications </td> </tr> </table>	<p>Standard</p> <ul style="list-style-type: none"> • (2) Open Collector Outputs Standard (150 mA max); Assignable to Pulse, Alarm, Timer, or Stopwatch • Digital Input for Remote Operation of a Single Task (Reset Total, etc.) 	<p>Options</p> <ul style="list-style-type: none"> • (2) Loop-Powered Solid-State Relays; Assignable to Alarm, Batch Control, Timer, or Stopwatch • Isolated 4-20 mA Analog Output • Modbus RTU RS-485 Communications
<p>Standard</p> <ul style="list-style-type: none"> • (2) Open Collector Outputs Standard (150 mA max); Assignable to Pulse, Alarm, Timer, or Stopwatch • Digital Input for Remote Operation of a Single Task (Reset Total, etc.) 	<p>Options</p> <ul style="list-style-type: none"> • (2) Loop-Powered Solid-State Relays; Assignable to Alarm, Batch Control, Timer, or Stopwatch • Isolated 4-20 mA Analog Output • Modbus RTU RS-485 Communications 		

Hazardous Area Pulse Input Flow Rate/Totalizers with Advanced Display and Control

The PD6938 ProtEX+ pulse input flow rate/totalizers can be installed in a variety of areas (hazardous, dirty, wet, corrosive, hot, or cold) to provide convenient and informative display of flow rate and total from any pulse output flowmeter. These instruments will accept a variety of pulse inputs, including slow pulse rates. They can be powered from a battery, 9-30 VDC, or the 4-20 mA output loop, have on-board datalogging capabilities, are available with explosion-proof and intrinsically safe approvals, and can be ordered with optional 4-20 mA output and two relays.

The PD6938, with the addition of its two optional relays, can also be used as a simple batch controller.

The PD6938 can operate down to -40°C and is certified by the agencies to be installed in areas that get as cold as -55°C. The display will cease functioning below -40°C but no damage will be done to the instrument.

One of the most convenient features of these instruments is their dual-line display, which is typically used to display the flow rate on the top display and flow total, flow grand total, or a tag on the bottom display. The top display has five characters and the bottom display has eight characters for clear indication of tags, units, or alarm messages. Further enhancing the display on these instruments is a 20-segment bargraph and backlighting that can turn red during an alarm condition.

The PD6938 ProtEX+ is available in aluminum and stainless steel enclosures that are designed for easy use and installation. The process connection is available in M20, 3/4" NPT and 1" NPT and there are two other conduit holes for field wiring. Field wiring is made to removable screw terminals and the display module can be oriented in 4 different positions to accommodate different mounting configurations and requires no tools to install. The display has been designed to optimize viewing angle.

Free, PC-based, [MeterView XL software](#) that connects to the meter via a micro-USB cable is available for programming and setup of the instruments. Four CapTouch through-glass buttons are available to operate the instrument without removing the cover.

All models come equipped with two open collector outputs and a digital input. There are also models available with Modbus RTU RS-485 communications, two solid-state relays, and isolated 4-20 mA analog output options. The open collector outputs are useful for alarm indication or pulse output. The digital input can be used to reset the total, to start/stop a timer/stopwatch, to start/stop a batch, and more. The relays can be programmed for alarm indication, on/off control, or simple batch control.

VantageView+ Series

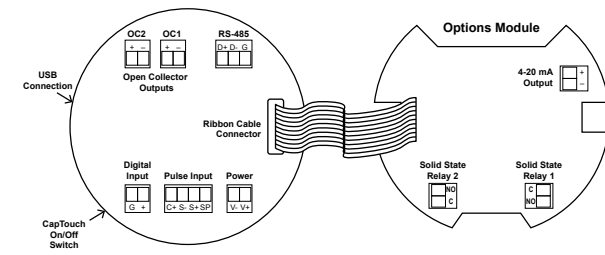
Front	Connections		
 <p>PD6938-GP-PL Flow Rate/Totalizer Plastic</p>	 <p>Connections for DC Powered -D5M Option</p> <table border="0"> <tr> <td style="vertical-align: top;"> <p>Standard</p> <ul style="list-style-type: none"> • (2) Open Collector Outputs Standard (150 mA max); Assignable to Pulse, Alarm, Timer, or Stopwatch • Digital Input for Remote Operation of a Single Task (Reset Total, etc.) </td> <td style="vertical-align: top;"> <p>Options</p> <ul style="list-style-type: none"> • (2) Loop-Powered Solid-State Relays; Assignable to Alarm, Batch Control, Timer, or Stopwatch • Isolated 4-20 mA Analog Output • Modbus RTU RS-485 communications </td> </tr> </table>	<p>Standard</p> <ul style="list-style-type: none"> • (2) Open Collector Outputs Standard (150 mA max); Assignable to Pulse, Alarm, Timer, or Stopwatch • Digital Input for Remote Operation of a Single Task (Reset Total, etc.) 	<p>Options</p> <ul style="list-style-type: none"> • (2) Loop-Powered Solid-State Relays; Assignable to Alarm, Batch Control, Timer, or Stopwatch • Isolated 4-20 mA Analog Output • Modbus RTU RS-485 communications
<p>Standard</p> <ul style="list-style-type: none"> • (2) Open Collector Outputs Standard (150 mA max); Assignable to Pulse, Alarm, Timer, or Stopwatch • Digital Input for Remote Operation of a Single Task (Reset Total, etc.) 	<p>Options</p> <ul style="list-style-type: none"> • (2) Loop-Powered Solid-State Relays; Assignable to Alarm, Batch Control, Timer, or Stopwatch • Isolated 4-20 mA Analog Output • Modbus RTU RS-485 communications 		

General Purpose Pulse Input Flow Rate/Totalizers with Advanced Display and Control

The PD6938 VantageView+ pulse input flow rate/totalizers can be installed in a variety of areas (dirty, wet, corrosive, hot, or cold) to provide convenient and informative display of flow rate and total from any pulse output flowmeter. These instruments will accept a variety of pulse inputs, including slow pulse rates. They can be powered from a battery, 9-30 VDC, or the 4-20 mA output loop, have on-board datalogging capabilities, and can be ordered with optional 4-20 mA output and two relays.

The PD6938, with the addition of its two optional relays, can also be used as a simple batch controller.

One of the most convenient features of these instruments is their dual-line display, which is typically used to display the flow rate on the top display and flow total, flow grand total, or a tag on the bottom display. The top display has five characters and the bottom display has eight characters for clear indication of tags, units, or alarm messages. Further enhancing the display on these instruments is a 20-segment bargraph and backlighting that can turn red during an alarm condition.

The PD6938 VantageView+ comes in a NEMA 4X, IP66 plastic enclosure that is designed for easy use and installation. There are three 3/4" NPT threaded conduit holes available for wiring. Two 3/4" NPT plastic conduit plugs are included. Field wiring is made to removable screw terminals and the display module can be oriented in 4 different positions to accommodate different mounting configurations and requires no tools to install. The display has been designed to optimize viewing angle.

Free, PC-based, [MeterView XL software](#) that connects to the meter via a micro-USB cable is available for programming and setup of the instruments. Four CapTouch through-window buttons are available to operate the instrument without removing the cover.

All models come equipped with two open collector outputs and a digital input. There are also models available with Modbus RTU RS-485 communications, two solid-state relays, and isolated 4-20 mA analog output options. The open collector outputs are useful for alarm indication or pulse output. The digital input can be used to reset the total, to start/stop a timer/stopwatch, to start/stop a batch, and more. The relays can be programmed for alarm indication, on/off control, or simple batch control.

DISPLAY FEATURES

PD6938 Pulse Input Flow Rate/Totalizer with Bargraph

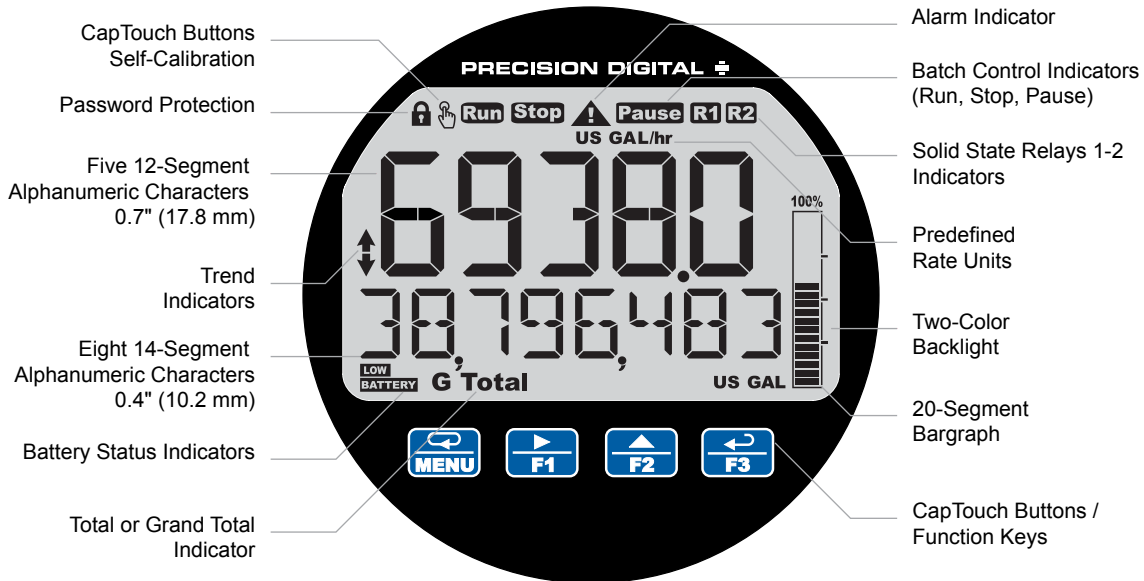

14-Segment Characters on Bottom Display Provide Clearer Readings of Units or Tags



Display Flow Rate & Total at the Same Time

One of the key features of these rate/totalizers is their ability to display flow rate and total at the same time. In addition, the meter can toggle between the rate and total and their corresponding units as the following illustrates.

Display Flow Rate & Total and Toggle Between Units

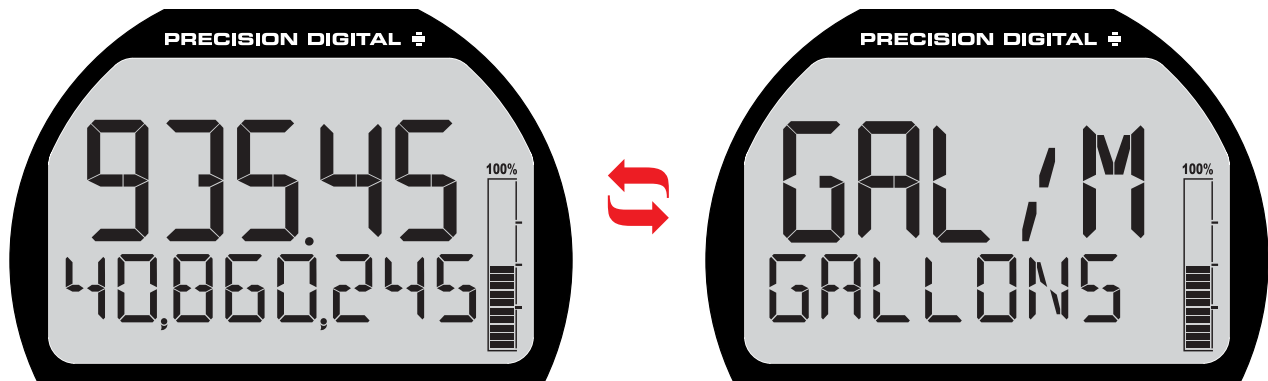

Flow Rate on Top & Total Flow on Bottom

Rate Units on Top & Total Units on Bottom

Wide Variety of Display Capabilities

In addition to the most common setup of flow rate on the top display and flow total on the bottom display, these meters can be set up for a variety of display configurations.

Display Flow Rate and Toggle Between Units & Tag

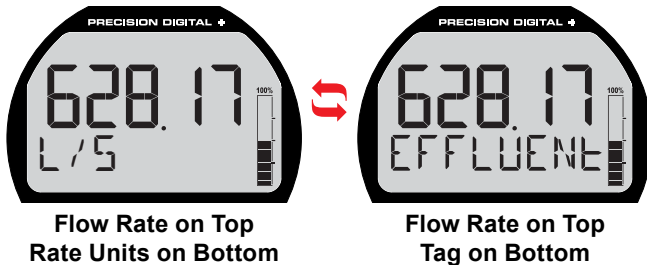

Flow Rate on Top
Rate Units on Bottom

Flow Rate on Top
Tag on Bottom

Display Flow Total and Toggle Between Units & Tag

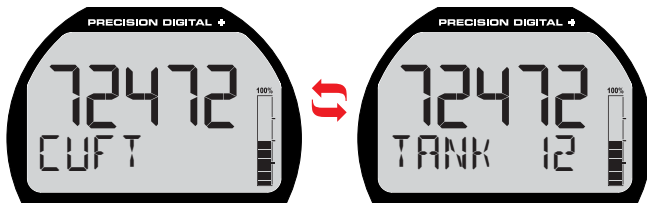

Total Flow on Top
Total Units on Bottom

Total Flow on Top
Tag on Bottom

Display Flow Total & Flow Grand Total and Toggle Between Units

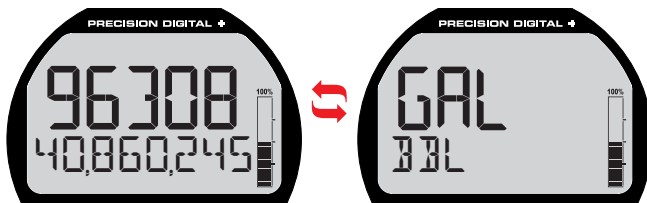

Total Flow on Top
Grand Total Flow on Bottom

Total Units on Top
Grand Total Units on Bottom

(note different units than Total)

The following table shows the items that can be displayed on the Top and Bottom lines:

Top (TOP) Line Can Display	
Off (Blank)	Preset batch value
Rate	Stopwatch
Rate and its units alternating	Timers OC and relays
Total	Min
Total and its units alternating	Max
Grand Total	Min & max
Tag	Time (12H or 24H format)
Units	Date
Bottom (BOTTOM) Line Can Display	
Off (Blank)	Preset batch value
Total	Units
Total with units alternating	Alarm message
Total and tag alternating	Stopwatch
Total, its units, and the rate and units alternating	Grand total, its units, and the rate units alternating
Grand total with units alternating	Grand total, units, and rate units alternating
Rate	Timers OC and relays
Rate with total units alternating	Min, Max, Min & max
Rate with units alternating	Rate percentage
Rate and tag	Input frequency
Rate or total units	mA output value
Tag	Time (12H or 24H format)
Tag and rate or total units	Date

14-Segment Characters

Notice how much better characters like “/” and “m” appear as 14-segment characters on the bottom display vs. 7-segment characters found on other meters.



7-Segment



14-Segment

Dual-Scale Display Feature

Users can use the dual-scale feature when they want to show the same input in two different scales. For instance, the following example shows an application where the meter displays the input in gallons per minute and cubic feet per minute.

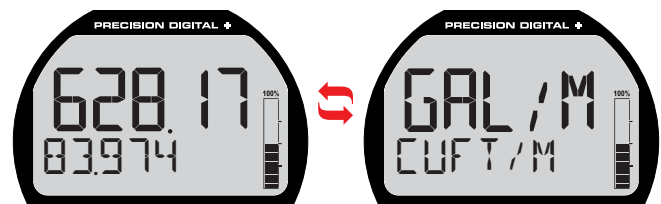

Rate in GPM on Top
Rate in CFM on Bottom

GPM Units on Top
CFM Units on Bottom

2X More Informative Display

The PD6938 Series display offers a 50% larger display area and is twice more informative than previous generations of loop-powered meters. Featuring an alphanumeric dual-line display and a 20-segment bargraph, reading and understanding process values is easy and intuitive. The addition of status indicators provides a quick glance at alarm conditions, relays, process trends, battery status, and more. Predefined display units give users even more display flexibility.

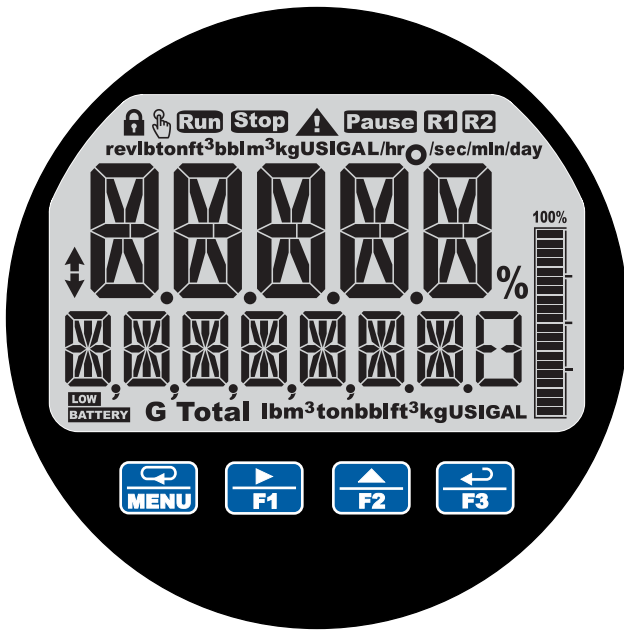

Indicator	State	Description
↕	Steady	Process trend arrows
▲	Flashing	Alarm Indicator
🔒	Steady	Password protected
R1	Steady	Solid-state relay 1
R2	Steady	Solid-state relay 2
👉	Flashing	CapTouch buttons self-calibrating (wait)
100% █	Steady	PV Bargraph
100% █	Flashing	Alarm condition: Bargraph segment flashes on alarm
Total	Steady	Displaying Total
G Total	Steady	Displaying Grand Total
Run	Steady	Batch is running
Run	Flashing	Automatic batch control: Batch paused or start delayed
Stop	Steady	Batch is stopped
Pause	Steady	Batch is paused
BATTERY	Flashing	Meter checking battery status
BATTERY	Steady	Meter using battery power
LOW BATTERY	Flashing	Low battery (replace battery)

Red, Flashing Display Gets People's Attention When Alarms Occur

When an alarm occurs, the display can be programmed to turn red, flash, and display an alarm indicator ▲. In addition, a unique custom alarm message for each of the two relays and two open collectors can be displayed on the bottom display. These features can be activated even if no relay or open collector is connected.

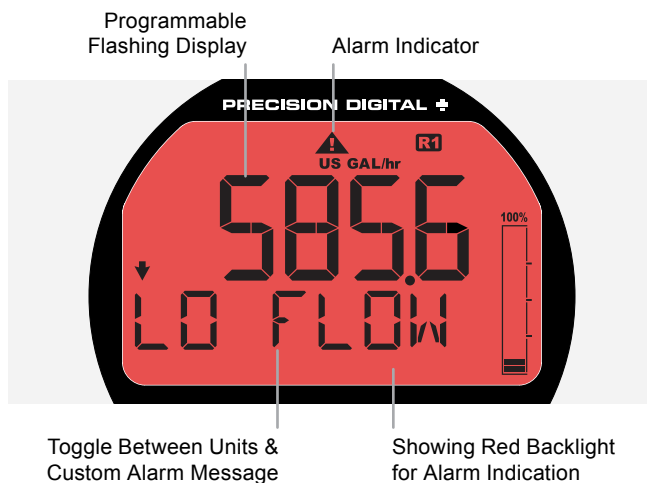

Commas Make it Easy to Read Big Numbers

The bottom display is set to show a comma separating the thousands and millions place by default if a numeric value is being displayed. This feature can be disabled or enabled using the *Comma* menu.

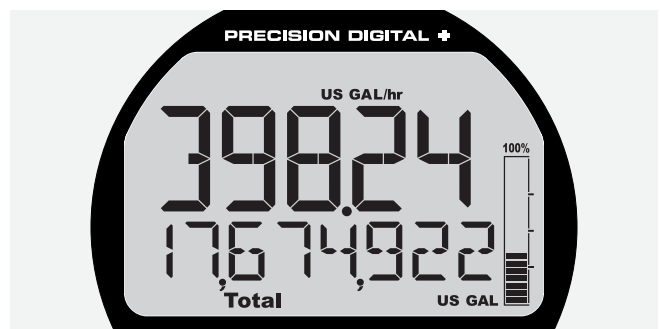

Backlight Turns Red on Alarm

The backlight is standard on all ProtEX+ and VantageView+ meters. It provides optimum visibility in any lighting condition and it can be programmed to turn red for alarm conditions. The backlight may be enabled or disabled using the *Backlight* menu. The backlight is enabled by default. If the meter is DC powered, then the backlight is constantly on. If the meter is battery powered, then the backlight is on according to the setting selected under the *System - Battery - Display* menu.

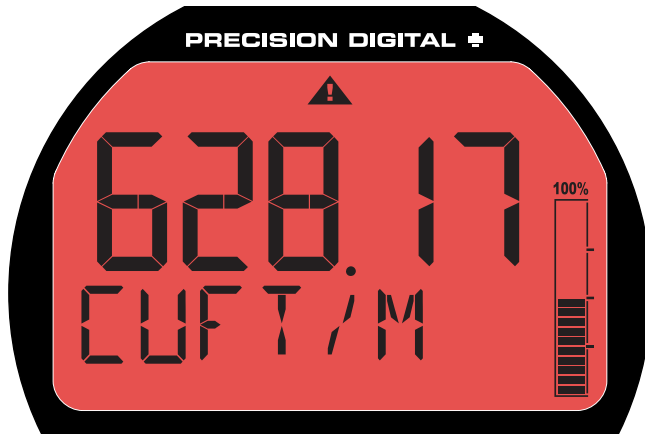

Backlight for Visibility in Any Lighting Condition and Red Backlight for Alarm Indications

Bargraph Provides Quick Understanding

The 20-segment bargraph helps users get a quick understanding of where their process is at. The bargraph can be programmed to represent either rate, a percentage of the rate, total, or it can be disabled.

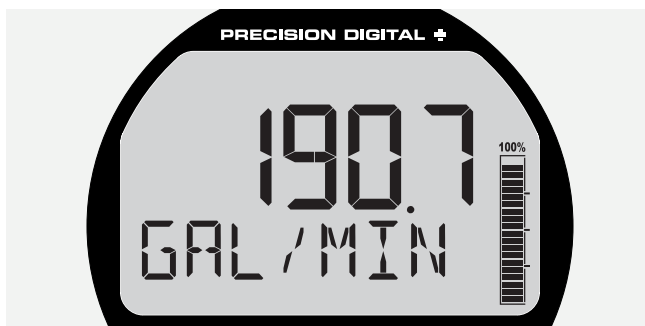

Bargraph indicating rate in gallons/minute

Total & Rate in Different Units

The user can select to display total in different units than the rate. For instance, a customer could measure flow rate in gallons per minute and total in acre-feet by simply selecting AF (acre-feet) units for the total. Additionally the user can enter a custom unit and conversion factor to display the total in any unit of measure.

Max/Min Display

The max & min readings (peak & valley) reached by the process can be displayed either continuously or momentarily.

- Display momentarily by pressing the F1 function key (default) or assigning to any of the other function keys or to the digital input in the User menu. Press Enter to lock/unlock max/min display.
- Display continuously by assigning either display line to max/min through the Display menu.

Any of the F1-F3 function keys (buttons) and the digital input can be programmed to reset the max & min readings.

Top Display: Process Value
Bottom Display: Max & Min

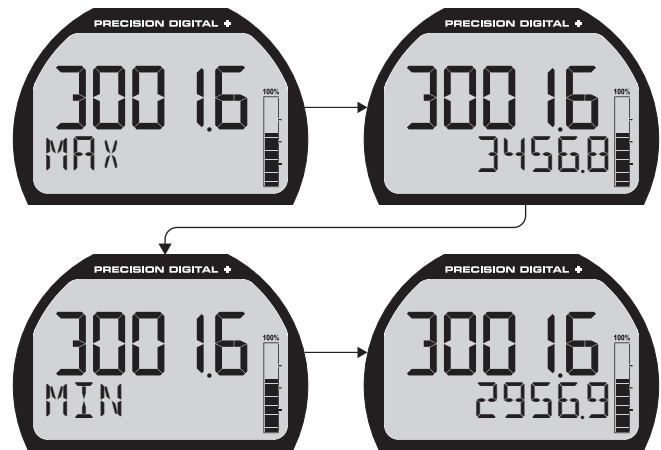

Using 13 Digits to Display Total

The top and bottom displays can be setup to display a 13-digit total (9,999,999,999,999). The total will roll over to zero when it exceeds the limit.

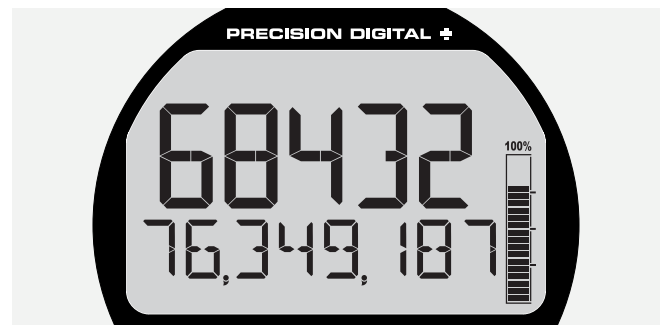

The number above should be read as 6,843,276,349,187

Predefined and Custom Units

The meter has the most common predefined rate and volume units. If the desired unit is not available, the user can program a custom unit.

CAPTOUCH THROUGH-WINDOW BUTTONS

All PD6938 meters are equipped with four capacitive sensors that operate as through-window buttons so that they can be operated without removing the cover (and exposing the electronics) in a hazardous area or harsh environment. CapTouch buttons are designed to work under any lighting condition and to protect against false triggering. They can be turned off for security via a switch on the display module.

To actuate a button, press one finger to the window directly over the marked button area. When the cover is removed or replaced, the CapTouch buttons can be used after the meter completes a self-calibrating routine (⌘ flashes). The sensors are disabled when more than one button is pressed, and they will automatically re-enable after a few seconds (⌘ off).



CapTouch Buttons Operation Modes

The CapTouch buttons have two modes of operation: *Normal* and *Delayed*.

Normal

Normal is the factory default setting. This mode is recommended for programming the meter or when immediate operation of the buttons is needed.

Delayed

Use the Delayed mode to prevent accidental trigger of the buttons. In the Delayed mode, the buttons enter into a low sensitivity state (sleep) and they ignore quick button presses after 20 seconds of inactivity. To wake up the buttons, press and hold any button for more than 2 seconds, the buttons respond normally.

Turning Off CapTouch Buttons

The CapTouch buttons can be turned off for security by moving the slide switch located on the display module to the Off position.



OUTPUTS

PD6938 meters come with two open collector outputs as standard and two solid-state relays and 4-20 mA output as options. The open collector outputs and relays generally operate in the same manner, with the major exception being the open collectors are not available for batch control and the relays are not available with pulse output features. The open collectors and relays can be controlled either automatically or manually. The alarm status (with a unique flashing red message for each of the two relays and open collectors) will show on the display even with no output wired.

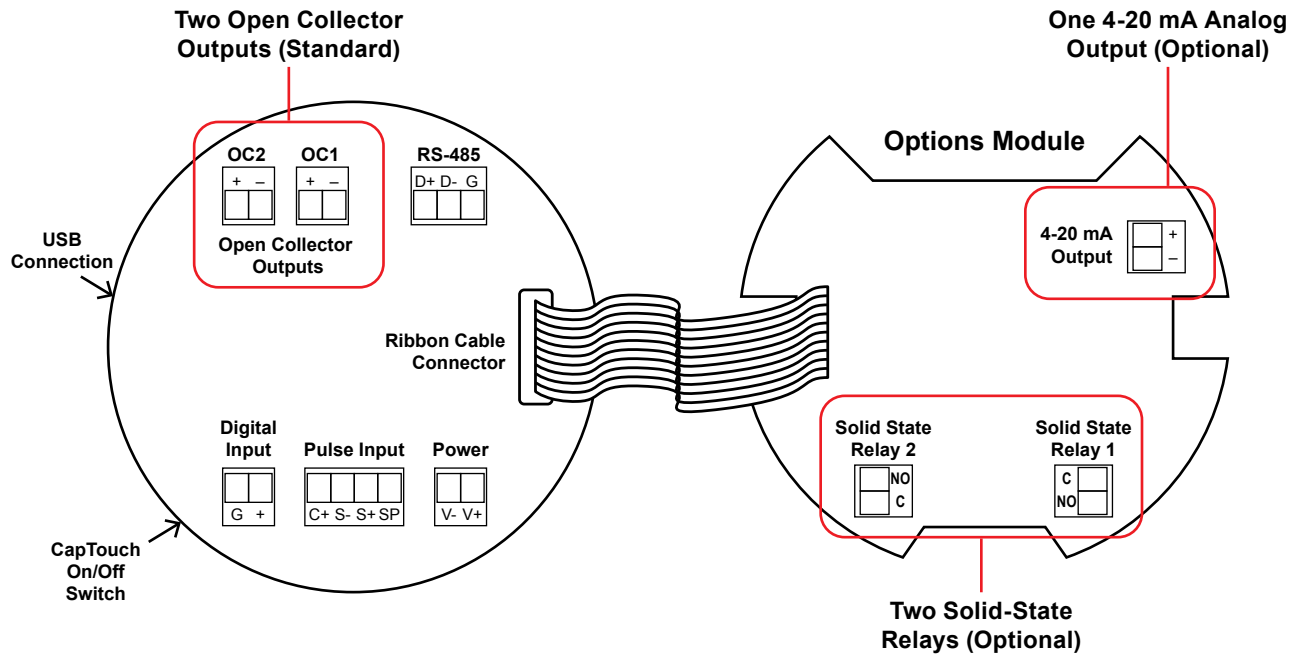

Two Open Collector Outputs

The meter is equipped with two NPN open collector outputs that may be set up for pulse outputs, alarms, timed pulses, stopwatch on/off, or disabled. Pulse outputs can be set to transmit the rate, total or grand total. Output 2 may be used to generate a quadrature output based on the other open collector output. An output test mode is also selectable to generate pulses at a constant programmable frequency. The open collectors are commonly used to generate a pulse for every user-defined amount of flow that has been generated. For instance, the meter can be programmed to generate a pulse for every 100 gallons of flow.

Two Optional Solid-State Relays

The meter is optionally equipped with two solid-state relays that may be set up for alarms, sample, timer, batch control, or stopwatch. The relays are rated at 250 VAC/DC @ 0.5 A for resistive loads and 38 VA @ 0.3 A, 250 VAC/DC max (Safe Area only) for inductive loads. Alarms are available based on the PV value or the digital input.

Optional Isolated 4-20 mA Output

The isolated analog output signal can be configured to represent the process variable (flow rate, total, or retransmit). While the output is nominally 4-20 mA, the signal will accurately accommodate under- and over-ranges from 1 to 23 mA. The output can be reverse scaled such that the meter's high calibration value outputs 4 mA and the meter's low calibration outputs 20 mA.

Sampling Relay

A relay set to sample will trigger when the total or grand total value has incremented by a programmed amount. The relay can be programmed to stay on for a specified amount of time. For example: if a relay is set to sample the total with a COUNT of 1,000 and a TIME of 10 seconds, the relay will energize for 10 seconds each time the total increments by 1,000 (e.g. 1000, 2000, 3000).

Resetting the Open Collectors and Relays

The open collectors and relays (alarms) may be programmed to reset in the following ways:

- **Automatic (AUTO):** Alarm will reset automatically once the alarm condition has cleared.
- **Automatic/Manual (AUTOMAN):** Alarm will reset automatically once the alarm condition has cleared but can also be reset using the Enter button (or whichever function key is set to acknowledge) at any time.
- **Latching (LATCH):** Alarm must be reset manually and can be done so at any time. Press the Enter (ACK) button at any time to clear the alarm.
- **Latching with Reset after Cleared (L-CLEAR):** Alarm must be reset manually and can only be done so after the alarm condition has cleared. Press the Enter (ACK) button after the alarm condition has cleared to reset the alarm.

Timer Function

Timers are used in everyday life; one of the most common examples is the microwave oven. Industrial timers are used in process control applications where certain events or actions need to be controlled by time. Examples include automatic batch control applications, where the relay needs to be energized for a specific length of time.

The timer function is available on the open collector and relay outputs; which means that you can have up to four timers per meter. The start and stop actions can be triggered from the setup menu or by the function keys and digital input. The meter can be setup to display the off/on timer count down.

There are two modes of operation:

- **Continuous Timer (Interval)**
At the start of the timer the output is off and turns on after the Off Delay elapses. The output remains on for the duration of the On Time. The cycle repeats until the user stops the timer either from the menu or a function key.
- **One-Shot Timer**
At the start of the timer the output is off and turns on after the Off Delay elapses. The output remains on for the duration of the On Time. The timer stops and the cycle does not repeat.

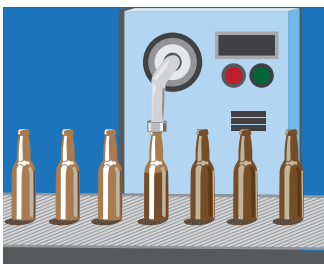

1. A sensor detects the bottle is in place and triggers the digital input to start the timer
2. The timer output controls the filling pump
3. The On Time is set according to the time needed to fill the bottle

BATCH CONTROL

The PD6938, when ordered with the two solid-state relays, can be used as a simple, one or two-stage batch controller. The user enters a preset and preclose value and sets the meter to either count up or count down. The top display will show the total and the bottom display will show the preset batch amount. The function keys are automatically changed so that F1 starts a batch, F2 opens the preset menu to allow the preset value to be changed, and F3 pauses/stops the currently running batch. Batching can be either automatic or manual.

Batch Control Operation Example

The following example shows how two-stage manual batch control functions with a PD6938. This setup will establish a 55-gallon preset for the batch, with a main valve (high flow) that will close at 50 gallons, and a trickle valve (low or restricted flow) that will close at 55 gallons. Because the first batch overruns by 0.10, the batch preset will be changed to 54.90 for the next batch to compensate for overrun.

Two-Stage Manual Batch Control Setup Using Relays 1 and 2

Parameter	Setting	Function
RELAY OUTPUT 1	RLY 1 BATCH	Press Enter to assign relay 1 batch parameters.
BATCH COUNT	UP or DOWN	Setup batch to count up or down.
BATCH MAXIMUM	10000 GAL	This setting prevents the operator from entering a preset value that exceeds a safety limit for the batch process.
BATCH MODE	MANUAL AUTO	Press Enter to select manual or automatic batch control.
BATCH PRESET	55.00 GAL	Enter the batch size.
BATCH DELAY	ON & OFF	Enter the On & Off time delays for relay 1, if desired.
RELAY OUTPUT 2	RLY 2 BATCH	Press Enter to assign relay 2 batch parameters.
BATCH PRECLOSE	YES PRECLOSE 500	Set the pre-close value to 5 to close the valve being controlled by relay 2 so it closes five gallons before reaching the preset.
BATCH DELAY	ON & OFF	Enter the On & Off time delays for relay 2, if desired.
RELAY MESSAGE	MSG RELAY 1	Enter a message to be displayed while relay 1 is on, if desired.
	MSG RELAY 2	Enter a message to be displayed while relay 2 is on, if desired.

If only one-stage batch control is desired, do not assign relay 2 to batch. The following pages show illustrations of how the above settings control the batch operation. The display assignment shown is the default.

Manual Batch Control

The manual batch control feature is used for batch processes that the operator wants to start manually. It can also be used where the batch size needs to be manually adjusted for each batch. The batch can be controlled by the button on the meter or the digital input.

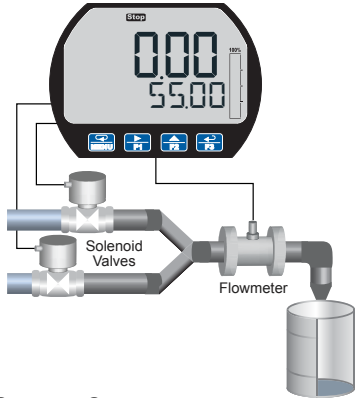

System Setup

Both valves are closed with an empty barrel in place. The batched total is displayed in the upper display, the preset is selected for the lower display.

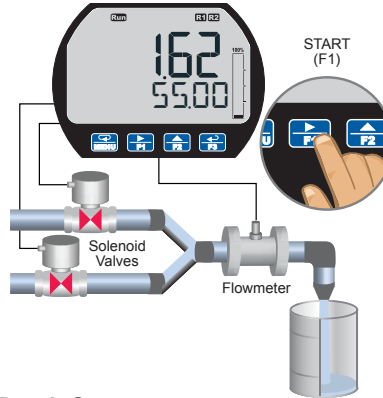

Batch Start

The START button or (F1) is pressed. Both valves open. The barrel begins to fill.

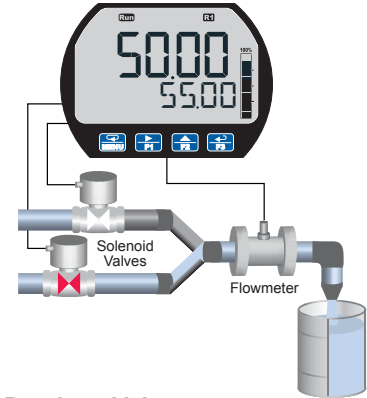

Preclose Valve

When the batch total reaches a value of 50.00 (Preset [55.00] – Pre-close [5.00]) the full-flow valve closes. The fill rate of the tank slows as a result.

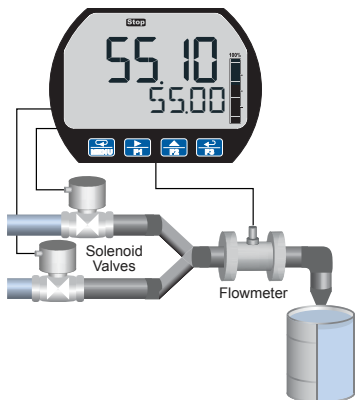

Completed Batch

When the batch is complete, the restricted flow valve closes. If overrun occurs, then the preset must be adjusted to compensate for the overrun amount. The next batch will only start after the START button or (F1) is pressed.

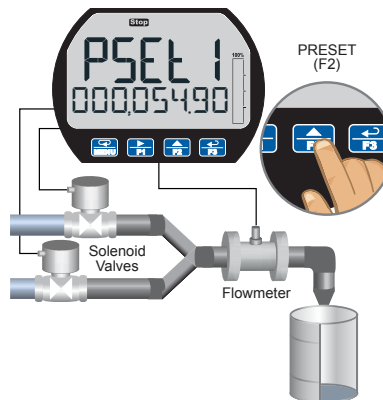

Overrun Correction

To compensate for overrun in the previous batch, adjust the preset to 54.90, so that the next batch is accurate (55.00).

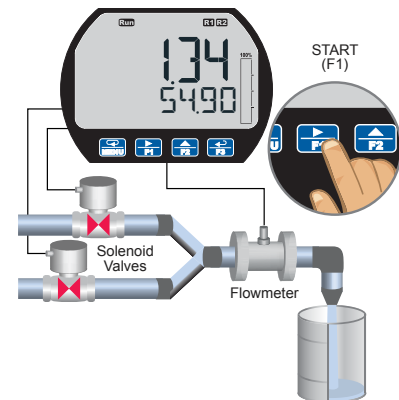

Manual Start of Next Batch

A new, empty, barrel is put in place and the START button or (F1) is pushed to manually start the next batch.

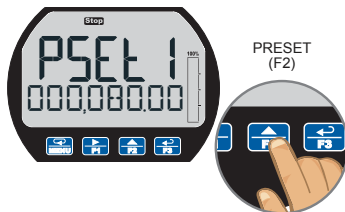

Change Batch Size

While the process is stopped, a new preset fill amount may be selected with the Batch key (F2) for a different size barrel.

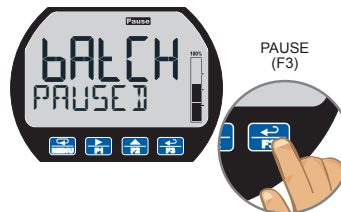

Pause/Stop

At any time, press the STOP button or Stop key (F3) once to pause the process, or twice to cancel the batch, which stops the process.

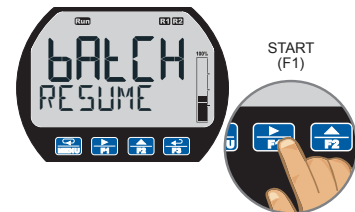

Resume Batch

If the batch has been paused, then press START button or (F1) to resume the batch process.

Automatic Batch Control

The automatic batch control feature is used for batches that start automatically once the previous batch is completed. There is no opportunity for the operator to change the batch size between batches. The batch can be controlled by the button on the meter or the digital input.

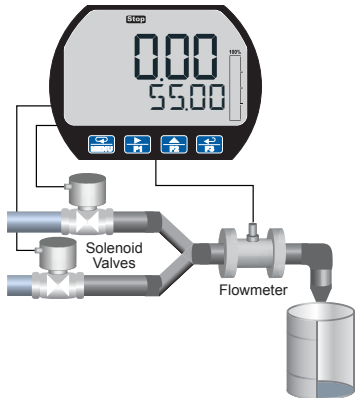

System Setup

Both valves are closed with an empty barrel in place. The batched total is displayed in the upper display, the preset is selected for the lower display.

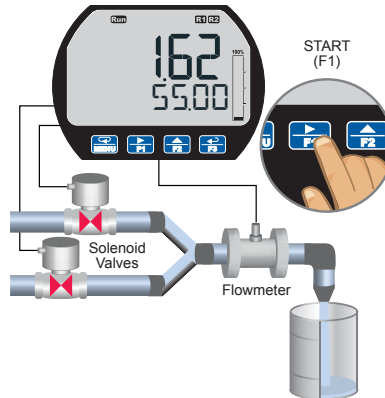

Batch Start

The START button or (F1) is pressed. Both valves open. The barrel begins to fill.

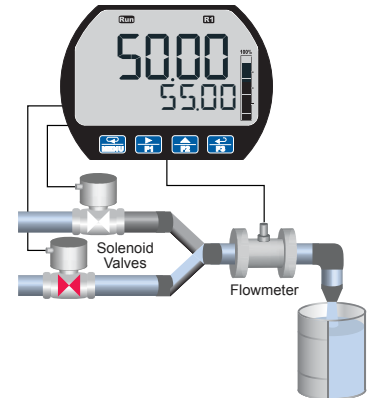

Preclose Valve

When the batch total reaches a value of 50.00 (Preset [55.00] – Pre-close [5.00]) the full-flow valve closes. The fill rate of the tank slows as a result.

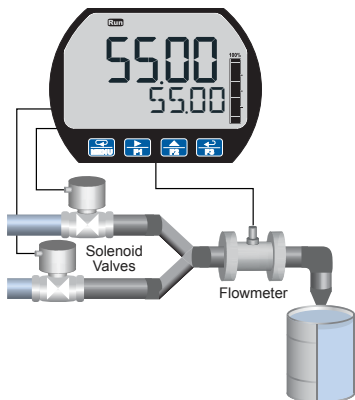

Completed Batch

When the batch is complete, the restricted flow valve closes. If overrun occurs, then the preset must be adjusted to compensate for the overrun amount.

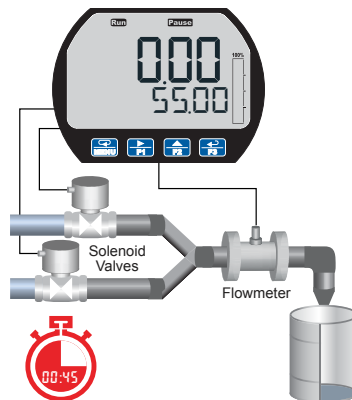

Start Delay

After the batch is completed, the operator removes the full barrel and places an empty barrel; the new batch starts automatically after 60 seconds (Time Delay).

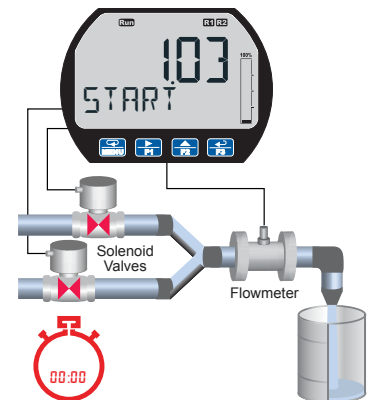

Automatic Start of Next Batch

The next batch begins automatically after 60 seconds, both relays activate and both valves open.

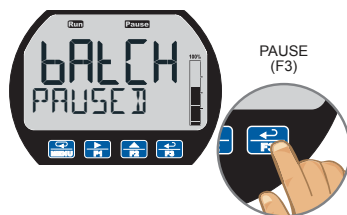

Pause

At any time, press the STOP button or Stop key (F3) once to pause the process.



Resume Batch

If the batch has been paused, then press START button or (F1) to resume the batch process.

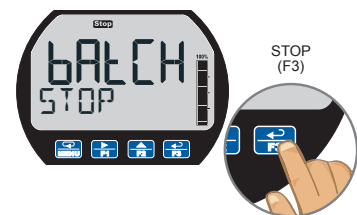

Stop Process

At the end of the shift, press STOP button or Stop key (F3) twice to stop the batch process.

TOTALIZER CAPABILITIES

PD6938 flow rate/totalizers can be programmed for a wide variety of totalizer applications. They can display total, grand total, or non-resettable grand total; the rate can be displayed with a time base of seconds, minutes, hours or days. The user can program a totalizer conversion factor, a non-resettable grand total, password protection, and several total reset methods.

8-Digit Total & Grand Total Display, Up to 13 Digits Using Both Lines

The flow rate/totalizer can be programmed to show eight full digits of total on the bottom display or 13 digits of total using both the top and bottom displays. In both cases, the display can be programmed to include commas to make it easier to read the very large numbers; ie 44,987,356.

In 13-digit mode, the bottom line shows the least significant digits and the top line shows the most significant digits. The meter is not capable of displaying commas on the top line, so this number is actually 1,211,230,379. The commas can be removed from bottom if desired. See sample on bottom, right.

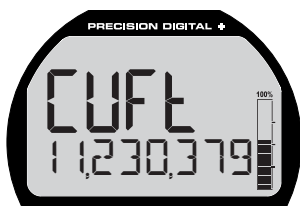

8 Digits of Total on Bottom

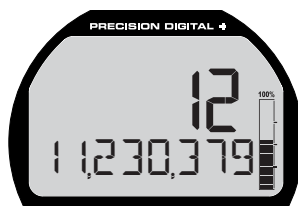

In 13-Digit Mode

Totalizer Conversion Factor & Multiplier

The user can enter a totalizer conversion factor that allows the meter to display total in different units than the rate. For instance, a customer could measure flow rate in gallons per minute and total in millions of gallons. A multiplier may be selected to automatically display the value in kGAL, MGAL, etc. Use the custom units to display the total in any unit of measure including units in languages other than English.

Totalizer Password Protection

The total and grand total can be password protected so they can be reset only by authorized personnel

Non-Resettable Grand Total

The user can set up the grand total to be non-resettable by selecting YES for PERMLOCK in the *Advanced - Grand Total - Reset* menu. Once this is done, the grand total can never be reset.

Remote Total Reset

The total can be reset via an external contact closure on the digital input.

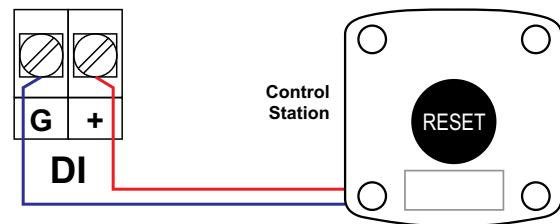

Front Panel Total Reset

The three front panel function keys can be programmed to reset the total and grand total. This makes it possible for the user to reset either the total or the grand total by pressing the appropriate function key. Of course, if the total or grand total is password protected, they will not reset when the function key is pressed unless the password is entered.



F2 Function Key is Programmed for Reset by Default

Total Alarms

The two open collectors and the two relays can be set up to alarm when the total reaches a user-defined set point. A variety of reset modes are available and the user can also program time delays and fail-safe operation.

Total Stored in Non-Volatile Memory

Total and grand total values, and all programmed settings are stored in non-volatile memory for a minimum of ten years if power is lost.

ADVANCED FEATURES

Automatic K-Factor Unit Calibration

The meter may be scaled using the K-Factor, or conversion factor, function. Most flowmeter manufacturers provide this information with the device. Enter the *K-Factor* menu and select the units defined with the K-Factor (example: pulses/gal), the decimal point with highest resolution possible, and program the K-Factor value. The meter automatically calculates the flow rate using the K-Factor value and the units selected. The rate can be displayed in any time-base and decimal point resolution selected in the Display menu.

Custom Scaling and Live Input Calibration

Instead of K-Factor setup, the meter can be scaled to any span relative to the input pulse rate span (i.e. if you knew the pulse input span for gallons but wanted to display the rate and total in liters). No external signal is required.

Live input calibration can also be performed. This is done at any two points along the scale. Using this method, an operator can set a “best fit straight line” for nonlinear input spans.

Multi-Point Linearization

Meters are set up at the factory for linear function with 2-point linearization. Up to 32 linearization points can be selected for rate under the linear function. Multi-point linearization can be used to linearize the input for non-linear signals to convert level to flow using weirs and flumes with complex equations.

MeterView XL makes it easy to program up to 32 points.

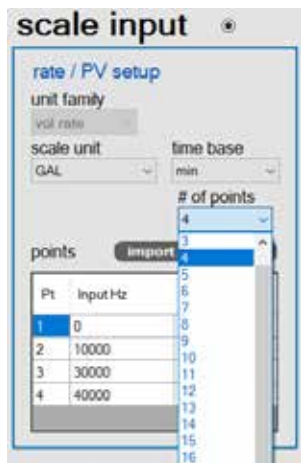

Low-Flow Cutoff

The user may program the meter for a low-flow cutoff such that the meter displays zero below this point, regardless of the input value.

Gate Function for Slow or Unsteady Pulses

The gate function allows for a rate display of slow or unsteady pulse rates. Using the programmable gate, the meter is able to display pulse rates as slow as 1 pulse every 9,999 seconds (0.0001 Hz). The gate function can also be used to obtain a steady display reading with a fluctuating input signal. There are two settings for the Gate, low gate and high gate.

Modbus® RTU Serial Communications

Select PD6938 models are available with Modbus RTU RS-485 communications and can communicate with any Modbus master device. Below are just some of the actions you can perform using Modbus.

- Read rate, total, grand total, max, and min display values
- Read the on-board 2,032 record data log
- Access all parameters remotely for programming or verification

Bi-Directional Flow

The PD6938 can be set up to process bi-directional flow by connecting the bi-directional switch from the flowmeter to the meter's digital input (DI) terminals, setting up the digital input to activate the flow function (Reversed or Forward), disabling the low-flow cutoff feature, and enabling negative count (if the total is expected to go negative).

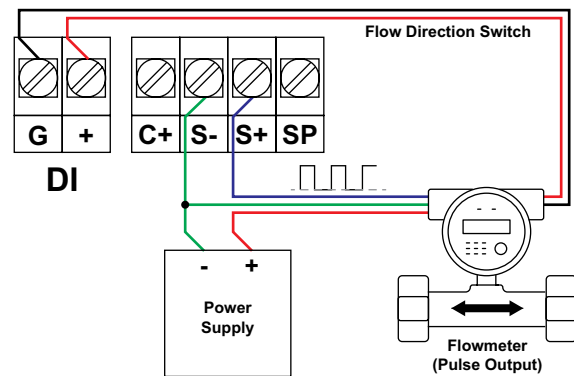

DATA LOGGING

The PD6938 is capable of data logging up to 2,032 records, each containing date, time, rate, total, grand total, relay & open collector states. The user can choose what information to log, when, and how to log it. The log file can be downloaded using the MeterView XL software and it can be saved in .csv file format.

Real Time Logging

A real time clock records the date and time for each data log entry. The data may be recorded using the Log Time feature up to 4 times per day at specific times entered by the user. When the log is full, it will roll over and continue to log, deleting the oldest data. The data may also be recorded using the Log Interval feature, recording the data every programmed time interval, from 1 minute to 24 hours.

When the Interval log is full, recording will stop, keeping all data until logging is started again.

Easy On-Screen Access

The data log entries are easily viewable on the meter LCD. Data points may be navigated by viewing the date and time, rate, total, or grand total amounts. A known log may be jumped to immediately, avoiding a lengthy search for data. With through-window buttons and a customizable menu, the data log can be accessed quickly and without the need for external control stations or serial communications, for easy viewing in the field.



On-Screen Log View Example

Data Log Setup with MeterView XL

The easiest way to set up the data logger is using the MeterView XL software connected via the micro-USB port or the RS-485 Modbus connection. There are many ways to log data using the on-board memory. Use the MeterView XL software to download the data or a Modbus application.

- Log time: Every day or any day of the week
- Log time interval: Select the logging interval
- Select to log continuously or stop when full



Data Log Example

The log file is saved in .csv file format and it contains all the information selected in the data log setup.

Date	Time	Flowrate	Source	Rate Units	Rate	Total	Grand Total	OC1	OC2	Relay1	Relay2
4	Apr/18/2020	00:07:07	0 OK2	100 GAl/Sec	1000 GAl	1000 GAl	1000 GAl	Alarm-Off	Alarm-Off	On	Off
5	Apr/18/2020	00:07:17	0 OK2	100 GAl/Sec	1000 GAl	1000 GAl	1000 GAl	Alarm-Off	Alarm-Off	On	Off
6	Apr/18/2020	00:07:27	0 Interval	100 GAl/Sec	1000 GAl	1000 GAl	1000 GAl	Alarm-Off	Alarm-Off	On	Off
7	Apr/18/2020	00:07:37	0 Interval	100 GAl/Sec	1000 GAl	1000 GAl	1000 GAl	Alarm-Off	Alarm-Off	On	Off
8	Apr/18/2020	00:07:47	0 Wt/L	100 GAl/Sec	1000 GAl	1000 GAl	1000 GAl	Alarm-Off	Alarm-Off	On	Off
9	Apr/18/2020	00:07:57	0 OK2	100 GAl/Sec	1000 GAl	1000 GAl	1000 GAl	Alarm-Off	Alarm-Off	On	Off
10	Apr/18/2020	00:08:07	0 OK2	100 GAl/Sec	1000 GAl	1000 GAl	1000 GAl	Alarm-Off	Alarm-Off	On	Off
11	Apr/18/2020	00:08:17	0 OK2	100 GAl/Sec	1000 GAl	1000 GAl	1000 GAl	Alarm-Off	Alarm-Off	On	Off
12	Apr/18/2020	00:08:27	0 OK2	100 GAl/Sec	1000 GAl	1000 GAl	1000 GAl	Alarm-Off	Alarm-Off	On	Off
13	Apr/18/2020	00:08:37	0 Wt/L	100 GAl/Sec	1000 GAl	1000 GAl	1000 GAl	Alarm-Off	Alarm-Off	On	Off
14	Apr/18/2020	00:08:47	0 Wt/L	100 GAl/Sec	1000 GAl	1000 GAl	1000 GAl	Alarm-Off	Alarm-Off	On	Off
15	Apr/18/2020	00:08:57	0 Wt/L	100 GAl/Sec	1000 GAl	1000 GAl	1000 GAl	Alarm-Off	Alarm-Off	On	Off
16	Apr/18/2020	00:09:07	0 Wt/L	100 GAl/Sec	1000 GAl	1000 GAl	1000 GAl	Alarm-Off	Alarm-Off	On	Off
17	Apr/18/2020	00:09:17	0 Interval	100 GAl/Sec	1000 GAl	1000 GAl	1000 GAl	Alarm-Off	Alarm-Off	On	Off
18	Apr/18/2020	00:09:27	0 Wt/L	100 GAl/Sec	1000 GAl	1000 GAl	1000 GAl	Alarm-Off	Alarm-Off	On	Off
19	Apr/18/2020	00:09:37	0 Wt/L	100 GAl/Sec	1000 GAl	1000 GAl	1000 GAl	Alarm-Off	Alarm-Off	On	Off
20	Apr/18/2020	00:09:47	0 Wt/L	100 GAl/Sec	1000 GAl	1000 GAl	1000 GAl	Alarm-Off	Alarm-Off	On	Off
21	Apr/18/2020	00:09:57	0 Interval	100 GAl/Sec	1000 GAl	1000 GAl	1000 GAl	Alarm-Off	Alarm-Off	On	Off
22	Apr/18/2020	00:10:07	0 Wt/L	100 GAl/Sec	1000 GAl	1000 GAl	1000 GAl	Alarm-Off	Alarm-Off	On	Off
23	Apr/18/2020	00:10:17	0 Wt/L	100 GAl/Sec	1000 GAl	1000 GAl	1000 GAl	Alarm-Off	Alarm-Off	On	Off
24	Apr/18/2020	00:10:27	0 Wt/L	100 GAl/Sec	1000 GAl	1000 GAl	1000 GAl	Alarm-Off	Alarm-Off	On	Off
25	Apr/18/2020	00:10:37	0 Wt/L	100 GAl/Sec	1000 GAl	1000 GAl	1000 GAl	Alarm-Off	Alarm-Off	On	Off
26	Apr/18/2020	00:10:47	0 Interval	100 GAl/Sec	1000 GAl	1000 GAl	1000 GAl	Alarm-Off	Alarm-Off	On	Off
27	Apr/18/2020	00:10:57	0 Wt/L	100 GAl/Sec	1000 GAl	1000 GAl	1000 GAl	Alarm-Off	Alarm-Off	On	Off
28	Apr/18/2020	00:11:07	0 Wt/L	100 GAl/Sec	1000 GAl	1000 GAl	1000 GAl	Alarm-Off	Alarm-Off	On	Off
29	Apr/18/2020	00:11:17	0 Wt/L	100 GAl/Sec	1000 GAl	1000 GAl	1000 GAl	Alarm-Off	Alarm-Off	On	Off
30	Apr/18/2020	00:11:27	0 Wt/L	100 GAl/Sec	1000 GAl	1000 GAl	1000 GAl	Alarm-Off	Alarm-Off	On	Off
31	Apr/18/2020	00:11:37	0 Wt/L	100 GAl/Sec	1000 GAl	1000 GAl	1000 GAl	Alarm-Off	Alarm-Off	On	Off
32	Apr/18/2020	00:11:47	0 Wt/L	100 GAl/Sec	1000 GAl	1000 GAl	1000 GAl	Alarm-Off	Alarm-Off	On	Off
33	Apr/18/2020	00:11:57	0 Interval	100 GAl/Sec	1000 GAl	1000 GAl	1000 GAl	Alarm-Off	Alarm-Off	On	Off
34	Apr/18/2020	00:12:07	0 Wt/L	100 GAl/Sec	1000 GAl	1000 GAl	1000 GAl	Alarm-Off	Alarm-Off	On	Off
35	Apr/18/2020	00:12:17	0 Wt/L	100 GAl/Sec	1000 GAl	1000 GAl	1000 GAl	Alarm-Off	Alarm-Off	On	Off
36	Apr/18/2020	00:12:27	0 Wt/L	100 GAl/Sec	1000 GAl	1000 GAl	1000 GAl	Alarm-Off	Alarm-Off	On	Off
37	Apr/18/2020	00:12:37	0 Wt/L	100 GAl/Sec	1000 GAl	1000 GAl	1000 GAl	Alarm-Off	Alarm-Off	On	Off

PHYSICAL FEATURES

ProtEX+ Aluminum & Stainless Steel Enclosures

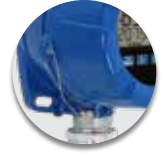
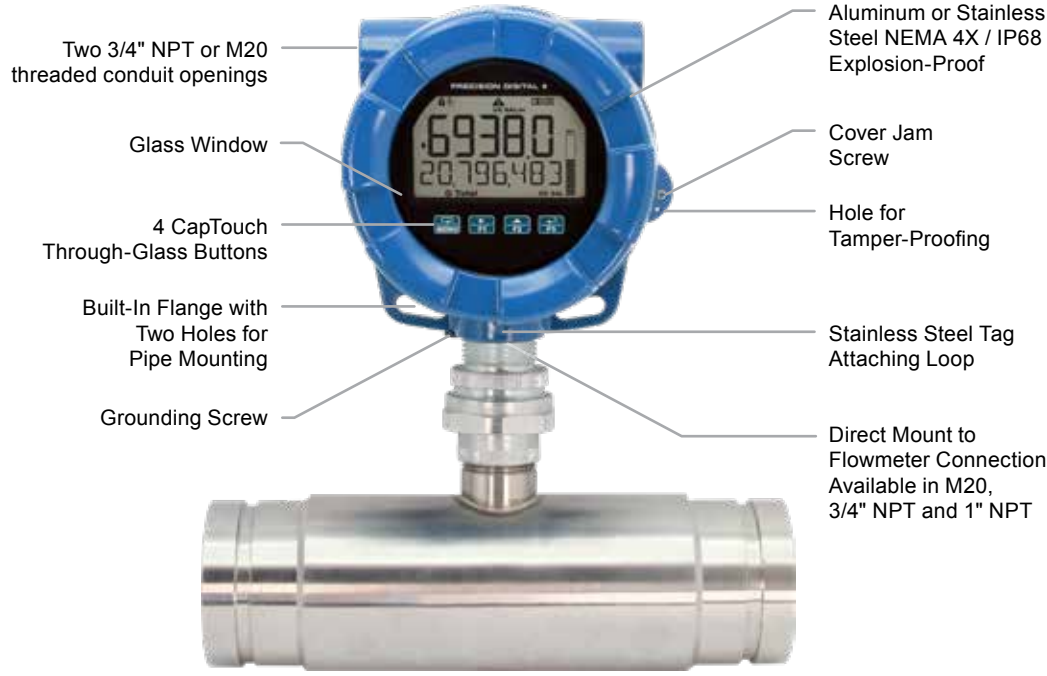

VantageView+ Plastic Enclosure

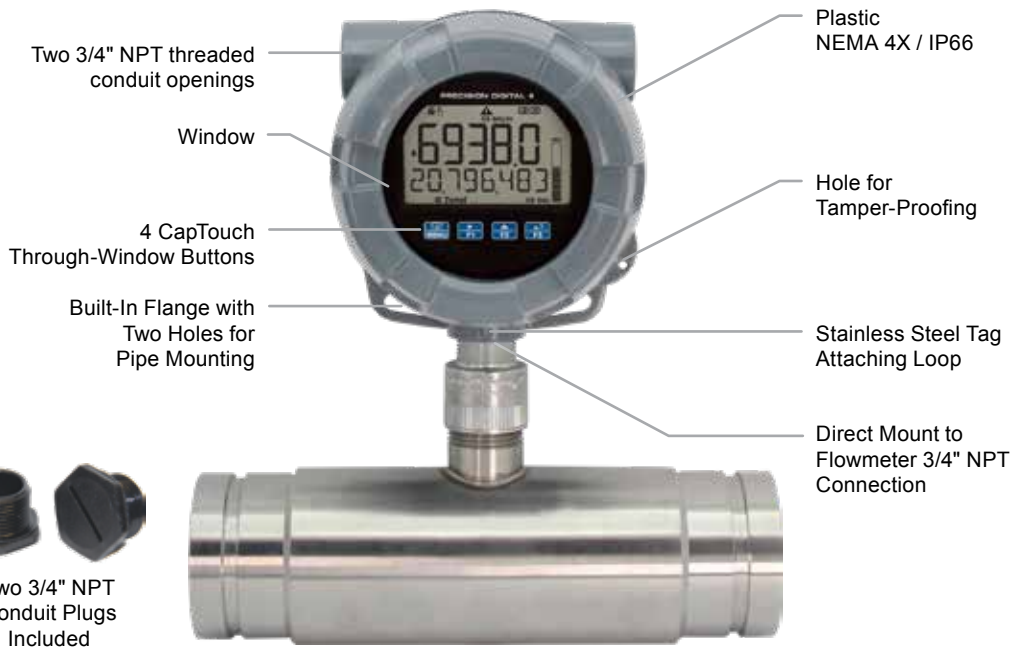

NEMA 4X Enclosures

Both ProtEX+ and VantageView+ enclosures provide serious protection from the elements, high impact, corrosion, and dust. The ProtEX+ is NEMA 4X/IP68 rated, and VantageView+ is NEMA 4X/IP66. In addition, the ProtEX+ enclosure provides protection against electrical interference and its extensive worldwide agency approvals allow it to be installed virtually anywhere.



Easy Pipe Mounting

Both ProtEX+ and VantageView+ come with a built-in flange. This allows easy mounting to walls or pipes using either a [PDA6846](#) Zinc Plated Steel or a [PDA6846-SS](#) Stainless Steel 2" U-Bolt Kit. A slot on the back of the enclosure makes it easy to center the unit on a pipe.



Stainless Steel Tag Attaching Loop

The enclosure is equipped with a loop at the bottom to easily attach a PDA-SSTAG stainless steel tag.



Tamper-Proof Capability

The instrument can be made tamper-proof by inserting a wire through the built-in loop on the base of the enclosure and a hole in the lid of the enclosure and securing this wire with a lead seal.



Rotatable Display Module

The display module can be rotated in 90° increments providing added mounting flexibility. Plus the various conduit connections allow a variety of installation options.



Wide Viewing Angle

The window and display module have been optimized to provide a wide viewing angle of approximately ±40°; nearly twice that of the competition.



Easy Wiring & Service

Both ProtEX+ and VantageView+ have been designed for easy wiring and servicing. All connections are made to removable screw terminal blocks. There are no exposed printed circuit boards. The display module snaps into the built-in rails on the enclosure ensuring a secure and perfect fit every time. No tools are needed to install or remove it. The options module is screwed into the base of the enclosure. Both modules completely encase the printed circuit boards.



Display Module



Options Module (Left) and Display Module (Right)



Options Module Mounted on the Bottom of Enclosure



Display Module Mounted on Built-In Rails (No Tools Required)

USB Port for Easy Connection to Free MeterView XL Software



Three Threaded Conduit Openings

The PD6938 ProtEX+ comes with three 3/4" NPT threaded conduit openings as standard. It's also available with M20 conduit openings, or with two 3/4" NPT and one 1" NPT bottom conduit openings. The VantageView+ comes with three 3/4" NPT threaded conduit openings and two conduit plugs included.



Direct Mounting

The PD6938 features a bottom threaded conduit opening that allows easy mounting directly to a flowmeter. The ProtEX+ is available with an M20, 3/4" NPT or 1" NPT bottom conduit opening. The VantageView+ features a bottom 3/4" NPT conduit opening.

This image shows a battery powered PD6938 mounted to a turbine flowmeter. Even though the unit is battery powered, it has a backlight that turns on only when CapTouch buttons are in use.



POWER OPTIONS

The PD6938 offers a wide range of power options including battery, DC with battery backup, DC only, output loop, or output loop with battery backup. See *Specifications* for details on each of the power options available. See *Ordering Information* for details on what power options are available for each hazardous area approval.

Battery Backup

Select models are available with a battery backup power option. For these models, the primary power source is supplied by either DC power or the output loop, depending on the model. The battery is used during battery backup operation. If there is a power failure of the primary power source, the battery will instantly take over powering the meter. There will be no display interruption nor any information loss.

Battery Status Indication

Battery indicators on the display alert users of the power status of the PD6938.

Indicator	State	Description
BATTERY	Flashing	Meter checking battery status
	Steady	Meter using battery power
LOW BATTERY	Flashing	Low battery (replace battery)

Designed for Long Battery Life

The PD6938 is designed with power savings in mind to help extend battery life.



LCD Sleep Mode

LCD sleep mode turns the LCD off after a user programmable amount of time, while all inputs and outputs continue working. Press any button for 2 seconds to wake up the display.



CapTouch Delayed Mode

In Delayed mode, the buttons enter into a low sensitivity state (sleep) after 20 seconds of inactivity. Press any button for 2 seconds to wake up the buttons.



Momentary Backlight

The backlight is enabled by default. If the meter is battery powered, then the backlight is automatically set up to momentarily turn on for 10 seconds when any button is pressed.



Turn Meter Off



To extend battery life even more, the meter can be turned off completely when it is not in use. Press and hold the Menu button for 5 seconds to turn the meter on or off and follow the on-screen instructions.

OPERATIONAL FEATURES

There are two ways the user can interact with the ProtEX+ and VantageView+ to perform a variety of useful functions: programmable function keys and the digital input.

Programmable Function Keys

The three CapTouch buttons labeled F1, F2, and F3 can be programmed as function keys to perform a variety of meter functions simply by pressing on the window over the button. These include resetting the total, operating the batch control functions, resetting the meter's relays or open collectors, starting and stopping timers, and displaying max/min values. The default settings for the function keys are:

Button	Description (Default Settings)
	Press to display grand total. Continue pressing to cycle through max, min, rate, and total displays.
	Press to access the Reset menu. Press F1 to scroll through the options. Press F3 to reset the currently displayed parameter.
	Press to acknowledge all manually resettable relays or open collectors. Press to lock/unlock the display value after pressing the F1 key.

For a complete list of Function Keys settings, see *Function Keys & Digital Input Available Settings* on the next page.

On-Board Digital Input

A digital input is standard on both ProtEX+ and VantageView+ meters. This digital input is programmed identically to the function keys. The input is triggered with a contact closure between DI+ and DI-, or with an active low signal. For a complete list of Digital Input settings, see *Function Keys & Digital Input Available Settings* on the next page.

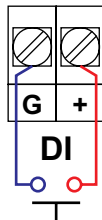

Remote Operation of VantageView+

The VantageView+ digital input can be connected to a [PDA2360](#) single button remote control station as illustrated below and be programmed to perform various functions. Common uses for this digital input would be for resetting the total, operating the batch control functions, resetting the meter's relays or open collectors, starting and stopping timers, and displaying max/min values. For a complete list of Digital Input settings, see *Function Keys & Digital Input Available Settings* on the next page.

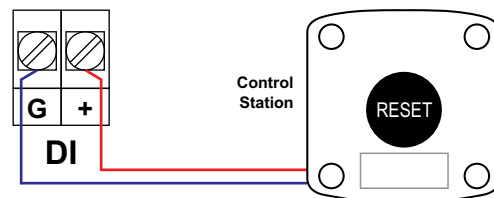

Available Single Button Control Stations



PDA2360-E



PDA2361-A



PDA2361-B



PDA2361-R



PDA2361-T



PDA2361-S



PDA2361-Q

WARNING

- Control Stations do not carry hazardous area approvals and are thus not suitable for location in hazardous areas.

Function Keys & Digital Input Available Settings

The following table describes the actions that the ProtEX+ and VantageView+ function keys and digital input can perform.

Display	Description
DISP FN	Set the function key or digital input to display a value
DISPLAY	Cycle max, min, rate, total, and grand total
RATE	Display the rate
TOTAL	Display the Total
DISP GT	Display the Grand Total
PCTRATE	Display the rate's percentage of max (20 mA)
UNITS	Display rate, total, and grand total units
TAG	Display the tags
DISPMIN	Display the minimum rate value
DISPMAX	Display the maximum rate value
MIN MAX	Display the minimum and maximum rate value
mA IN	Display the mA input value
mA OUT	Display the mA output value
MENU FN	Set the function key or digital input to access a menu
RLYINFO	Go to relay information menu (INFO)
MANCTRL	Go to output control menu (CONTROL)
TIMR OC1	Open collector 1 timer
TIMR OC2	Open collector 2 timer
TIMER R1	Relay 1 timer
TIMER R2	Relay 2 timer
TIMERFN	Set the function key or digital input to start or stop a timer
STARTALL	Start all timers
STOPALL	Stop all timers
SSTPALL	Start or stop all timers
OC1	Start/stop open collector 1 timer
OC2	Start/stop open collector 2 timer
RLY1	Start/stop relay 1 timer
RLY2	Start/stop relay 2 timer
START	Start the selected timer output
STOP	Stop the selected timer output
STR--STP	Start or stop the selected timer output

Display	Description
BATCHFN	Set the function key or digital input to batch control
START	Start a batch
STOP	Stop a batch
STR--STP	Start or stop
PRESET	Preset batch amount
ALARMFN	Set the function key or digital input to acknowledge an alarm
ACK	Acknowledge all active alarms
SETPINT	Set all output set point
SETPOC1	Set open collector 1 set point
SETPOC2	Set open collector 2 set point
SETPR1	Set relay 1 set point
SETPR2	Set relay 2 set point
SWATCHFN	Set the function key or digital input to activate stopwatch
START	Start the stopwatch
STOP	Pause/Stop the stopwatch
STR--STP	Start or stop the stopwatch
HOLD FN	Set the function key or digital input to hold an output
HOLDOUT	Hold all outputs
HOLDUNHOLD	Hold or un-hold all outputs
OC1+2	Hold/un-hold open collector outputs
RLY1+2	Hold/un-hold relay outputs
mAOUT	Hold/un-hold 4-20 mA output
HOLD	Hold selected output
HOLDUNHOLD	Hold or un-hold selected output
DISABLE	Disable the function key or digital input
RST FN	Set the function key or digital input to reset a value
RESET	Reset min, max, or max/min PV value
R MINMAX	Reset max and min PV value

METERVIEW XL PROGRAMMING SOFTWARE

Free, PC-based, MeterView XL software that connects to the meter via a micro USB cable is available for programming and setup of the meters. This software greatly simplifies the programming process and also allows the user to save configuration files for later use. The meter will also be powered by the USB connection so no additional power is needed during programming.

For more information visit
www.predig.com/meterviewxl



⚠ WARNING

- The meter should only be connected to a computer while it is located in a safe area.

Main Screen

The main screen displays an image of the connected meter and includes various information about this meter, such as model number, readings, and status.

Input/Scale

The Input/Scale window is used to set the input, scale the input, and enable/disable the dual-scale feature.



Relay Output

The Relay Output window is used to assign a specific task to the 2 relays such as alarm, batch control, sample, timer, stopwatch, or off. A custom message that flashes every 10 seconds can also be added.



4-20 mA Output

The 4-20 mA Output window is used to program the isolated 4-20 mA output's source, range, and under and over range values.



Data Logging

MeterView XL software, when connected to the meter, can generate a log file such as the following example.

Date & Time	rate	units	grand total units
2/22/2021 12:51	4.67	GAL/sec	20 GAL
2/22/2021 12:52	7.32	GAL/sec	119 GAL
2/22/2021 12:52	9.94	GAL/sec	262 GAL
2/22/2021 12:52	12.68	GAL/sec	455 GAL
2/22/2021 12:52	15.34	GAL/sec	687 GAL
2/22/2021 12:53	18.01	GAL/sec	963 GAL
2/22/2021 12:53	20.67	GAL/sec	1283 GAL
2/22/2021 12:53	23.3	GAL/sec	1646 GAL
2/22/2021 12:54	25.95	GAL/sec	2053 GAL
2/22/2021 12:54	28.59	GAL/sec	2504 GAL
2/22/2021 12:54	31.37	GAL/sec	3014 GAL
2/22/2021 12:54	34.04	GAL/sec	3555 GAL
2/22/2021 12:55	36.68	GAL/sec	4139 GAL
2/22/2021 12:55	39.3	GAL/sec	4766 GAL
2/22/2021 12:55	42.05	GAL/sec	5458 GAL
2/22/2021 12:56	44.75	GAL/sec	6175 GAL
2/22/2021 12:56	47.4	GAL/sec	6936 GAL
2/22/2021 12:56	50.06	GAL/sec	7740 GAL
2/22/2021 12:56	52.67	GAL/sec	8588 GAL
2/22/2021 12:57	55.39	GAL/sec	9508 GAL
2/22/2021 12:57	58.08	GAL/sec	10445 GAL
2/22/2021 12:57	60.74	GAL/sec	11425 GAL
2/22/2021 12:57	63.38	GAL/sec	12450 GAL
2/22/2021 12:58	66.11	GAL/sec	13551 GAL
2/22/2021 12:58	68.75	GAL/sec	14664 GAL
2/22/2021 12:58	71.4	GAL/sec	15821 GAL
2/22/2021 12:59	74.08	GAL/sec	17022 GAL

Configuration Files

A configuration file can be generated with or without a meter connected to the PC. This makes it possible to prepare meter configurations prior to having the meter in hand. Meter configurations can be saved and re-loaded into other meters. Meter configurations can also be printed.

ACCESSORIES

PDA6846 2" U-Bolt Kits



The PDA6846 U-Bolt Kits provide a convenient way to mount the meter to 1.5" or 2" pipes. They are available in steel and stainless steel.

Model	Description
PDA6846	2" Zinc Plated Steel U-Bolt Kit with One U-Bolt
PDA6846-SS	2" Stainless Steel U-Bolt Kit with One U-Bolt

PDA-SSTAG Stainless Steel Tag



The PDA-SSTAG is a laser etched stainless steel tag that can be customized with three lines of text. Each tag comes with a stainless steel wire and lead seal for easy mounting wherever you need.

Model	Description
PDA-SSTAG	Stainless Steel Tag

24 VDC Transmitter Power Supply



The [PDA1024-01](#) 24 VDC power supply can be used to power the PD6938 and the 4-20 mA output. It can be mounted on a [PDA1002](#) DIN rail.

Model	Description
PDA1024-01	24 VDC Transmitter Power Supply
PDA1002	6" DIN Rail Mounting Kit

Specifications

Input Voltage	85-264 VAC; 120-370 VDC
Output Voltage	21.6-29 VDC; 1.5 A rated current.
Input Frequency	47-63 Hz
AC Current	115 VAC: 0.88 A; 230 VAC: 0.48 A
Connections	Screw terminals
Overload Protection	105-160% rated output power. Constant current limiting, recovers automatically after fault condition is removed
Operating Temperature	-30 to 60°C (-22 to 140°F)
Vibration	10-500 Hz, 2G 10 min./1 cycle, period for 60 min. each along X, Y, Z axes
Safety Standards	UL 508 Listed and UL Recognized Component
Dimensions	1.40" x 3.50" x 2.10" (35 mm x 90 mm x 54.5 mm) (W x H x D)
Warranty	1 year parts & labor

WARNING

- PDA1024-01 does not carry hazardous area approvals and is thus not suitable for location in hazardous areas. The use of additional protective devices may allow it to be installed in a safe area and connected to a device in a hazardous area. User should consult a professional engineer to determine suitability of these products for their specific application.

Plugs



PDAPLUG75 3/4" NPT and PDAPLUGM20 M20 316 stainless steel stopping plugs with approvals are available for ProtEX+ meters. PDAPLUG75P 3/4" NPT plastic conduit plug is available for VantageView+ meters.

Model	Description
PDAPLUG75	3/4" NPT 316 Stainless Steel Stopping Plug with Approvals for ProtEX+
PDAPLUG75P	3/4" NPT Plastic Conduit Plug for VantageView+
PDAPLUGM20	M20 316 Stainless Steel Conduit Plug with Approvals

Reducers



The following reducers are available for ProtEX+ meter.

Model	Description
PDAREDUCER-75M-50F	M-3/4" NPT to F-1/2" NPT Reducer with Approvals
PDAREDUCER-75M-M20F	M-3/4" NPT to F-M20 Reducer with Approvals

Plastic Control Stations

The PDA2360 series of plastic control stations provide a convenient way to remotely control devices. The VantageView+ digital input can be wired to any of the following control stations to perform a single task.

Model	Description
PDA2360-E	Emergency Button
PDA2361-A	Ack Button
PDA2361-B	Blank Button
PDA2361-R	Reset Button
PDA2361-T	Tare Button
PDA2361-S	Stop Button
PDA2361-Q	Silence Button

Notes:

- Control stations can be connected directly to the meter's Digital Input terminals labeled DI+ and DI-.



PDA2360-E



PDA2361-A



PDA2361-B



PDA2361-R



PDA2361-T



PDA2361-S



PDA2361-Q

WARNING

- Control Stations do not carry hazardous area approvals and are thus not suitable for location in hazardous areas. The use of additional protective devices may allow them to be installed in a safe area and connected to a device in a hazardous area. User should consult a professional engineer to determine suitability of these products for their specific application.

DIMENSIONS

ProtEX+

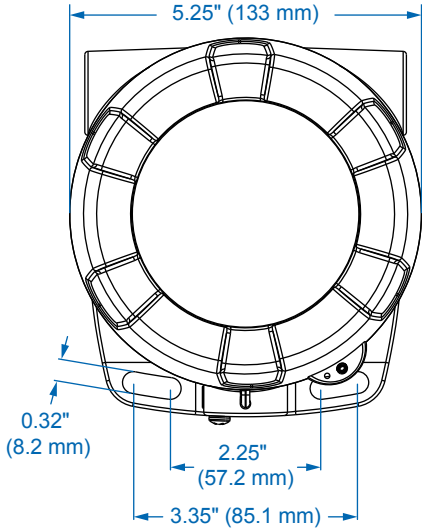

Front View

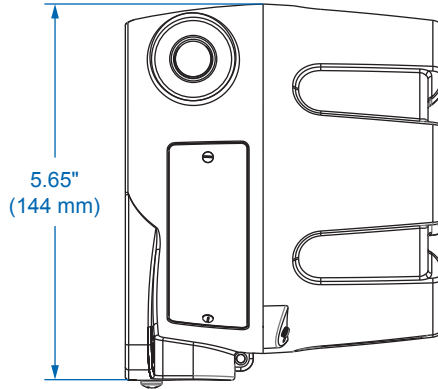

Side View

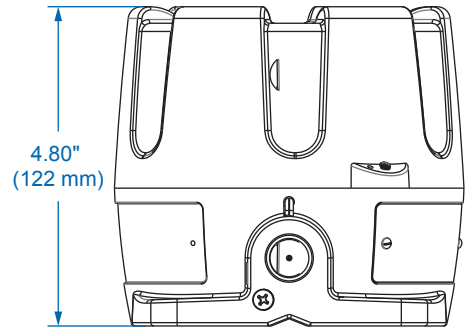

Bottom View

VantageView+

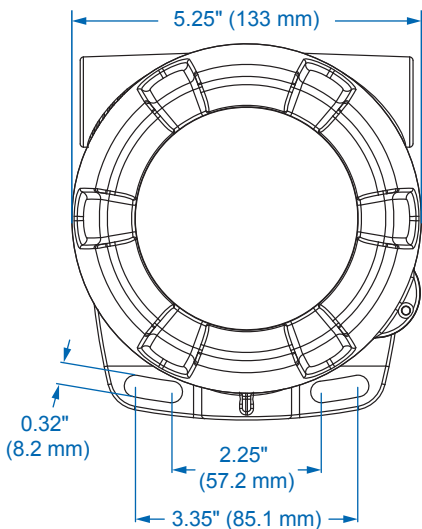

Front View

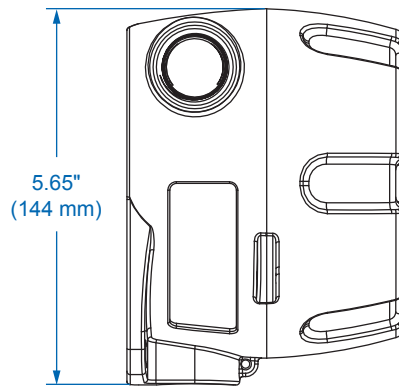

Side View

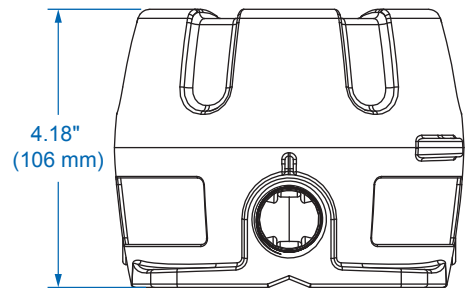

Bottom View



Download free 3-D CAD files of these instruments to simplify your drawings!

predig.com/documentation-cad

CONNECTIONS

DC Powered Models (-D Option)

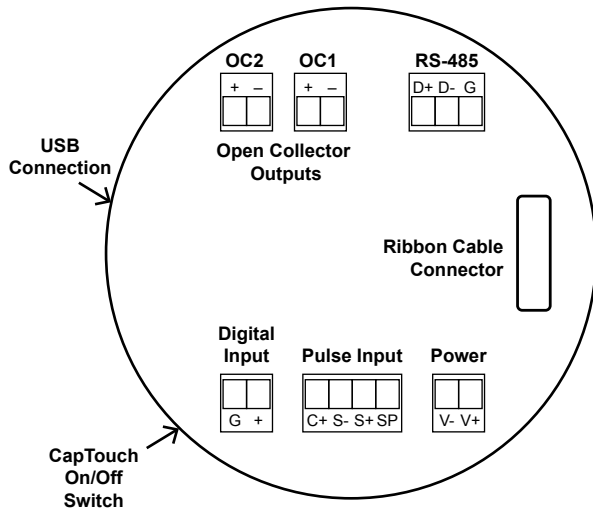

Open Collectors, Digital Input, RS-485, DC Power	
Connector	Description
OC1	Open Collector 1
OC2	Open Collector 2
RS-485	RS-485 Modbus RTU
Digital Input	G, +
Power	V+, V- (9-30 VDC)
Pulse Input	
Connector	Description
C+	Magnetic Pickup Coil
S-	Signal -
S+	Signal +
SP	Sensor Power (5 V @ 5 mA)

-DNM Base Meter (2 Open Collectors and RS-485 Modbus RTU Standard)

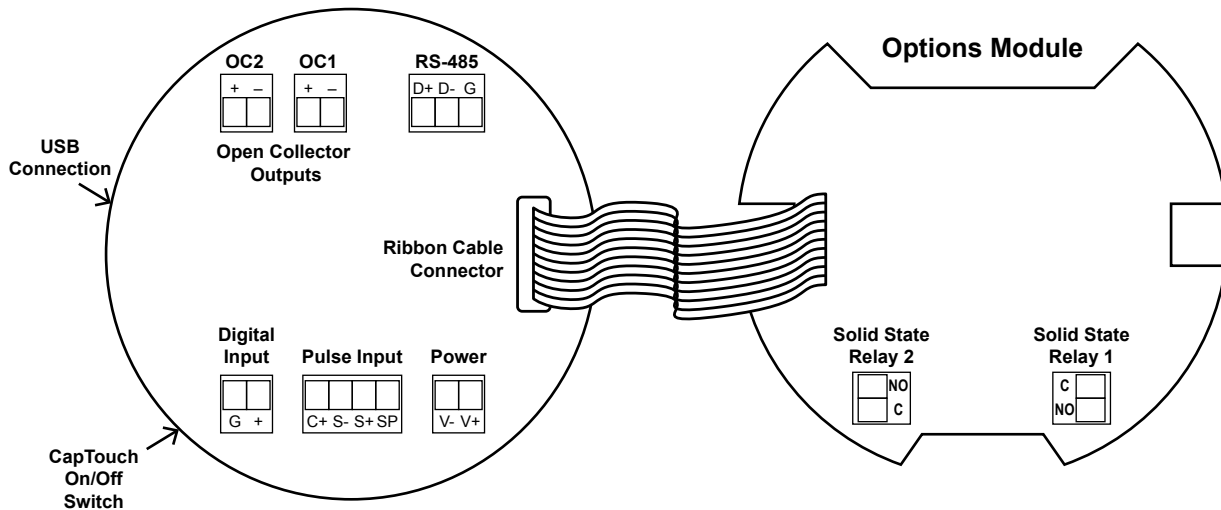

-D2M Option (2 Solid-State Relays)

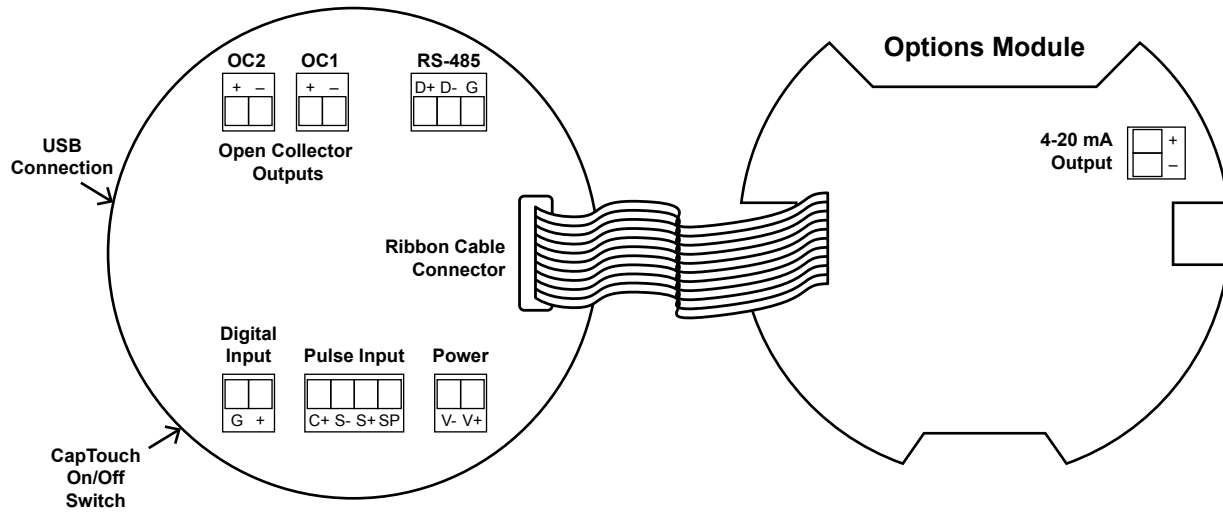

-D3M Option (4-20 mA Output)

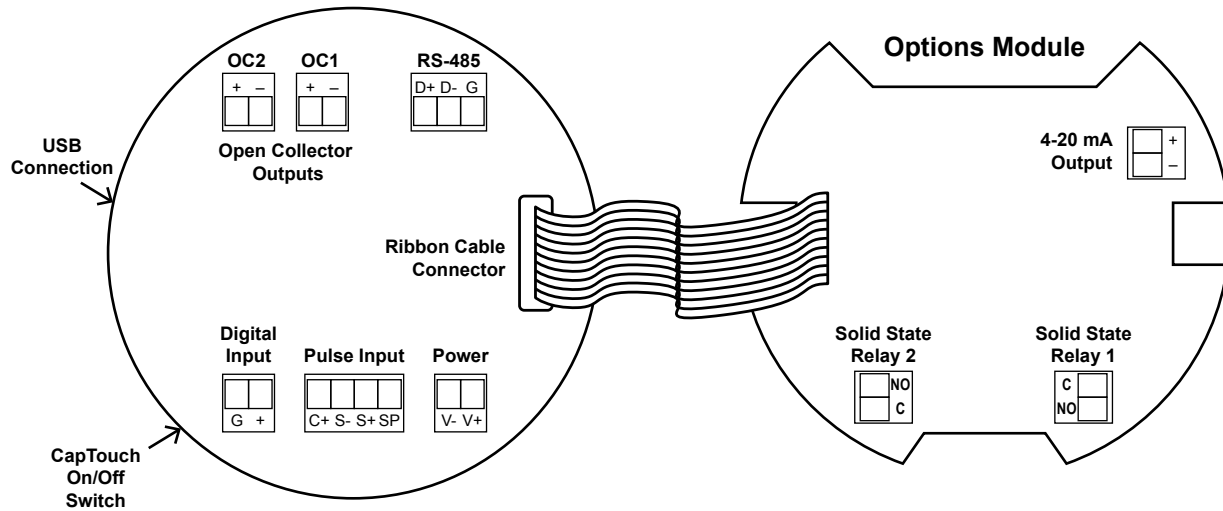

-D5M Option (2 Solid-State Relays and 4-20 mA Output)

DC Powered with Battery Backup Models (-A, -B, -P Options)

Open Collectors, Digital Input, RS-485, DC Power	
Connector	Description
OC1	Open Collector 1
OC2	Open Collector 2
RS-485	RS-485 Modbus RTU
Digital Input	G, +
Power	V+, V- (9-30 VDC)

Pulse Input	
Connector	Description
C+	Magnetic Pickup Coil
S-	Signal -
S+	Signal +
SP	Sensor Power (5 V @ 5 mA)

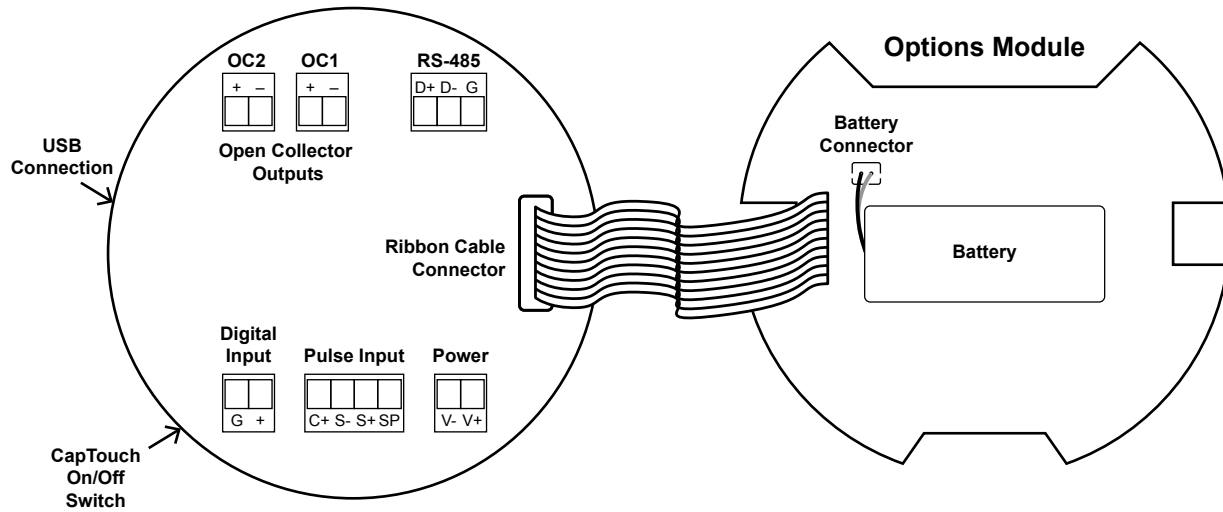

-ANM, -BNM, -PNM Base Meter (2 Open Collectors and RS-485 Modbus RTU Standard)

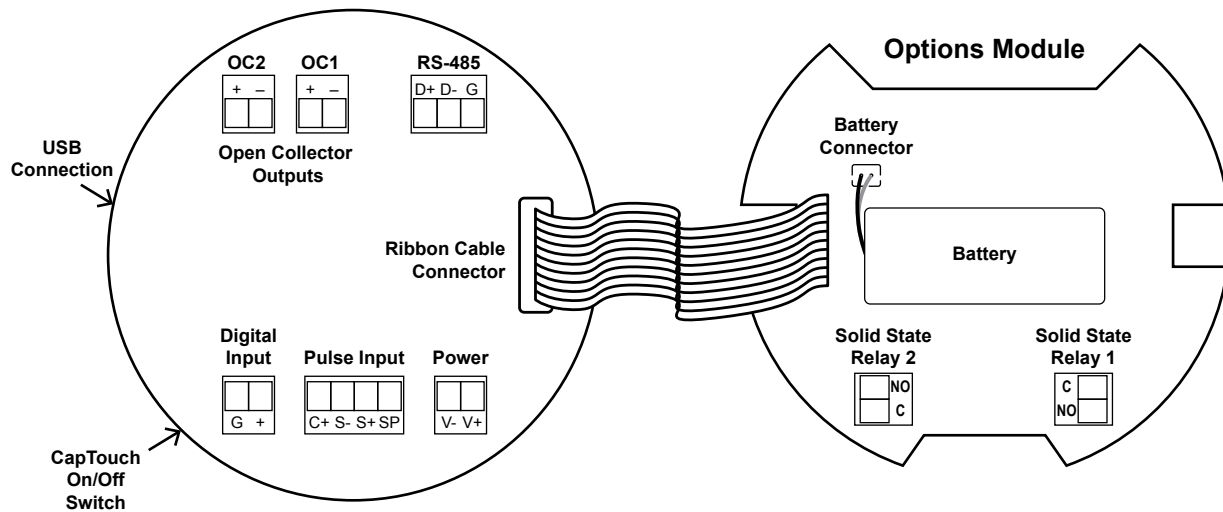

-A2M, -B2M, -P2M Options (2 Solid-State Relays)

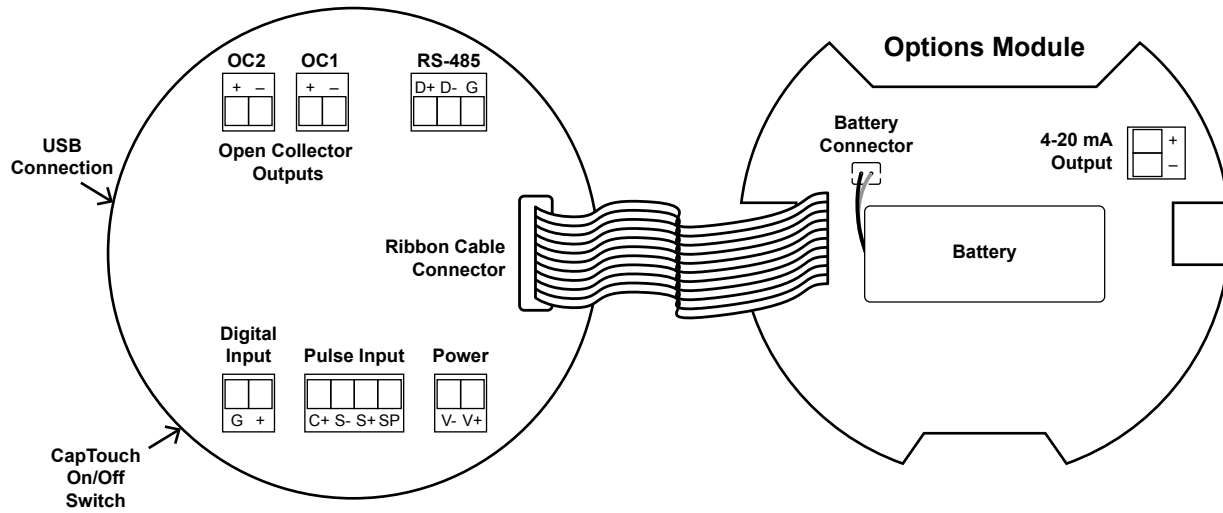

-A3M, -B3M, -P3M Options (4-20 mA Output)

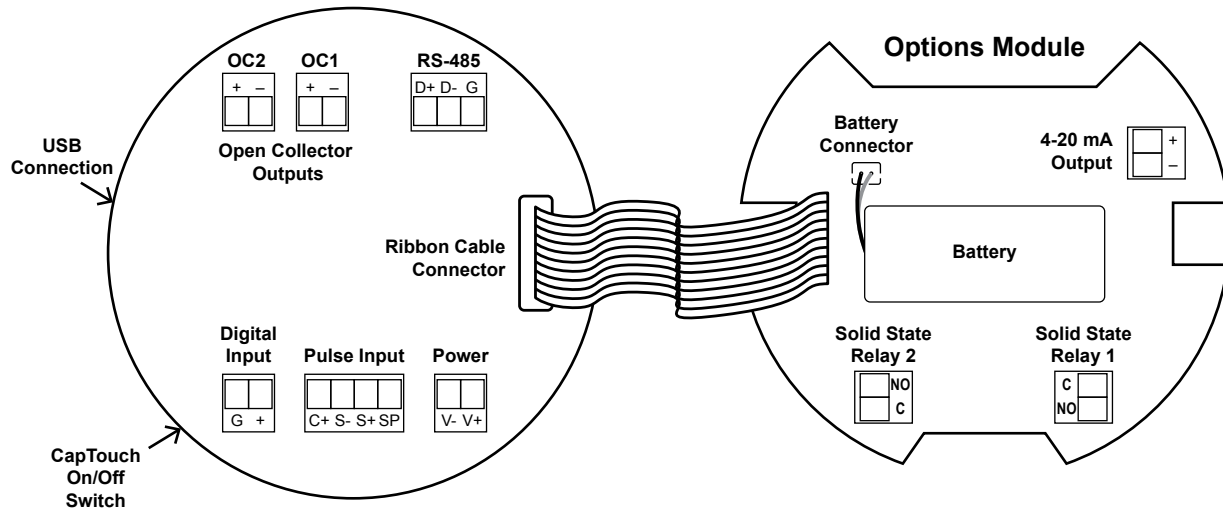

-A5M, -B5M, -P5M Options (2 Solid-State Relays and 4-20 mA Output)

Loop Output Powered Models (-C Option)

Open Collectors and Digital Input	
Connector	Description
OC1	Open Collector 1
OC2	Open Collector 2
Digital Input	G, +

Pulse Input	
Connector	Description
C+	Magnetic Pickup Coil
S-	Signal -
S+	Signal +
SP	Sensor Power (5 V @ 5 mA)

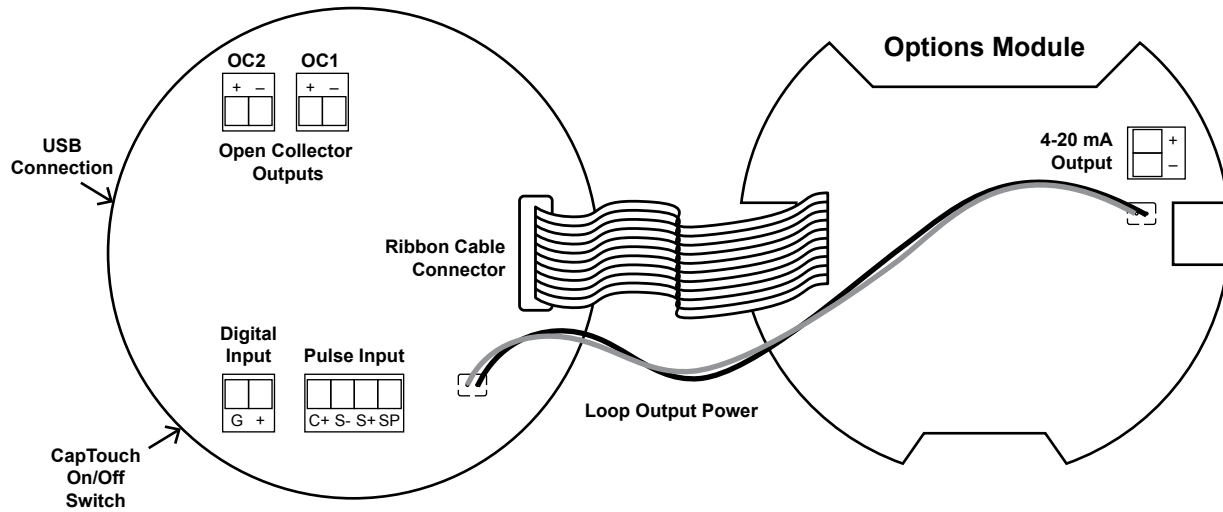

-C3N Base Meter (2 Open Collectors Standard + 4-20 mA Output)

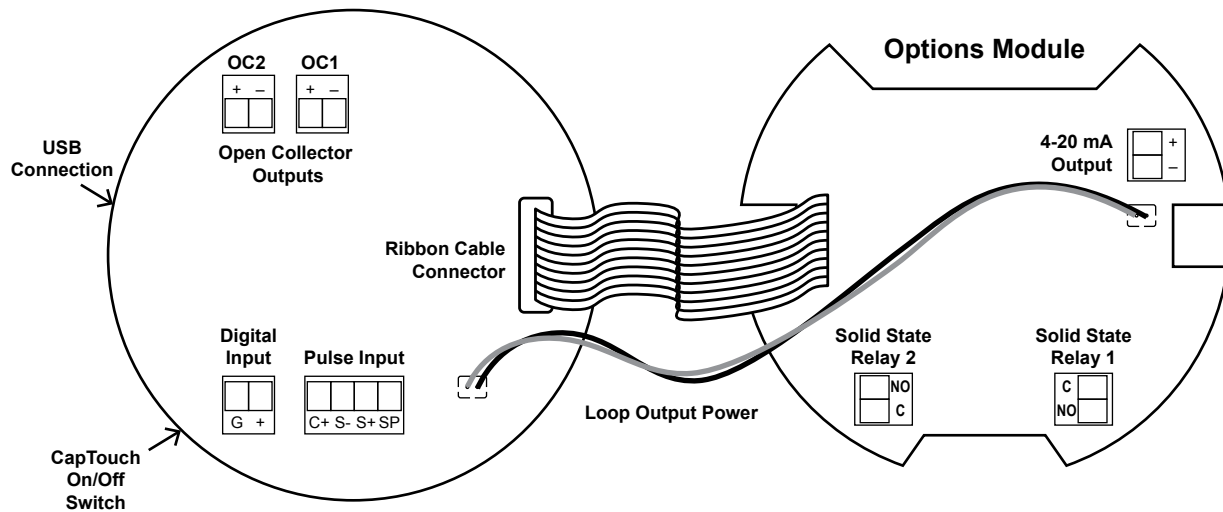

-C5N Option (2 Solid-State Relays and 4-20 mA Output)

Loop Output Powered with Battery Backup Models (-R, -M, -N Options)

Open Collectors and Digital Input	
Connector	Description
OC1	Open Collector 1
OC2	Open Collector 2
Digital Input	G, +

Pulse Input	
Connector	Description
C+	Magnetic Pickup Coil
S-	Signal -
S+	Signal +
SP	Sensor Power (5 V @ 5 mA)

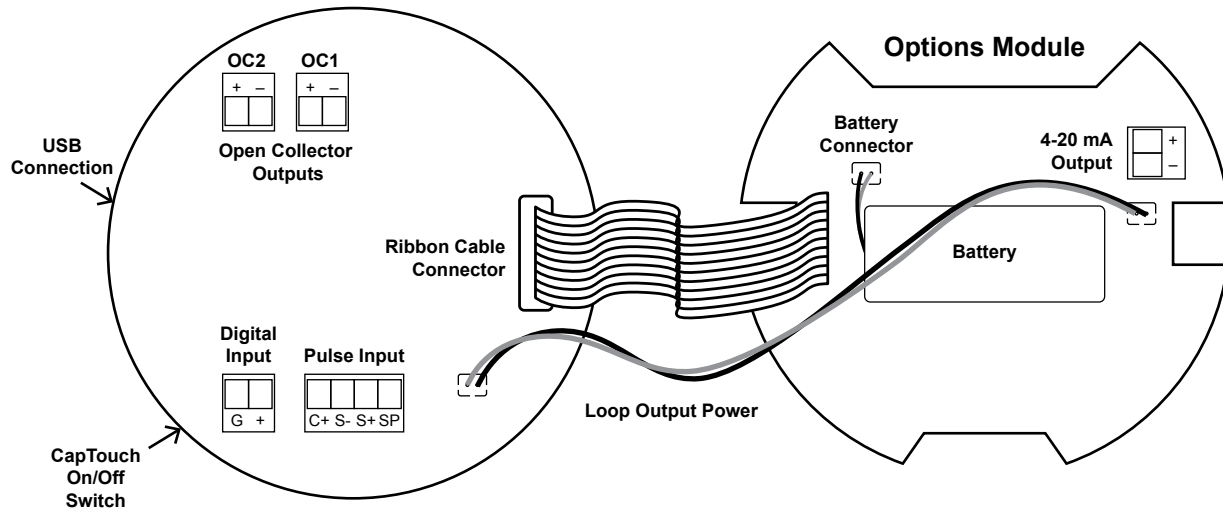

-R3N, -M3N, -N3N Base Meter (2 Open Collectors Standard + 4-20 mA Output)

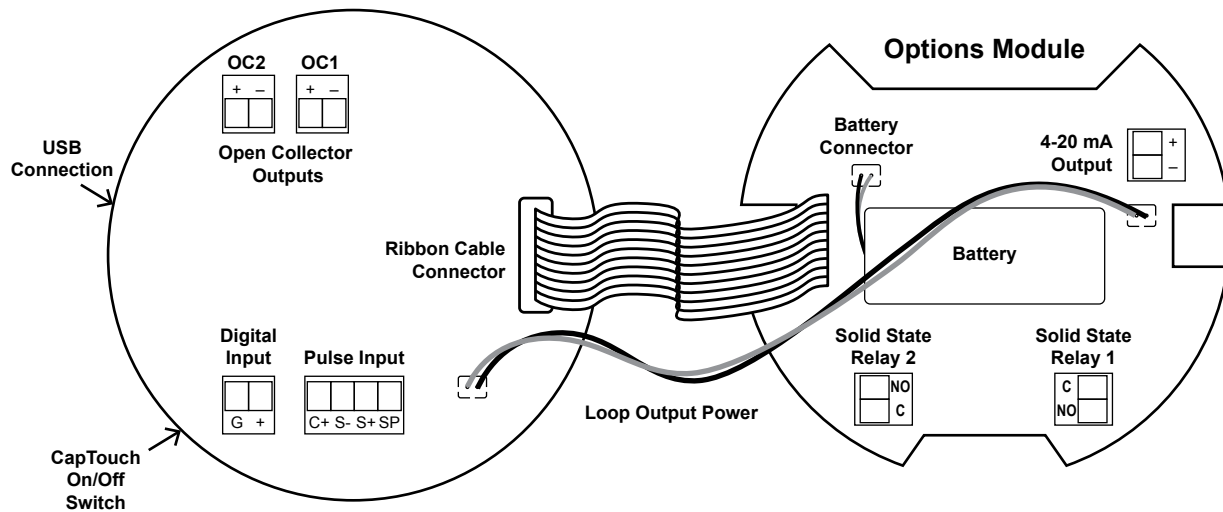

-R5N, -M5N, -N5N Options (2 Solid-State Relays and 4-20 mA Output)

WIRING DIAGRAMS

Intrinsically Safe Wiring (-HA and -IS Models)

⚠ WARNING

- PD6938 installation must be performed in accordance with control drawings included in [LIM6938-2](#), in order to meet agency approval ratings.
- For ATEX certification, barrier and transmitter must be ATEX Certified with Entity Parameters and must be connected per manufacturer's instructions.
- Service requiring replacement of internal components must be performed at the factory.
- Entire meter assembly (electronic assembly) may be replaced in the field with a unit supplied from the factory labeled "Field Modification".

Explosion-Proof Wiring (-HA and -EX Models)

Pulse Input Connections

Signal connections are made to a four-terminal connector. The following figures show connections to various flowmeter types. There are no switches or jumpers to set up for the input. Setup and programming are performed through the CapTouch buttons or PC-based software.

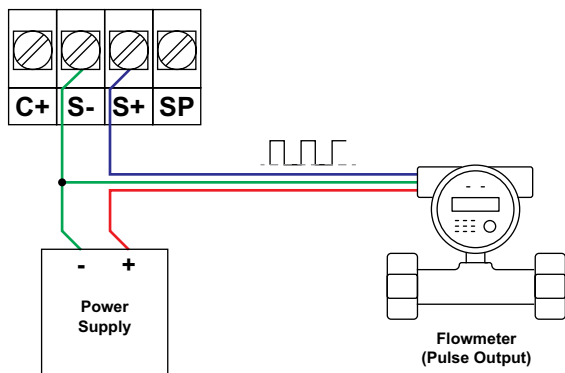

Flowmeter Powered by External Supply (Active)

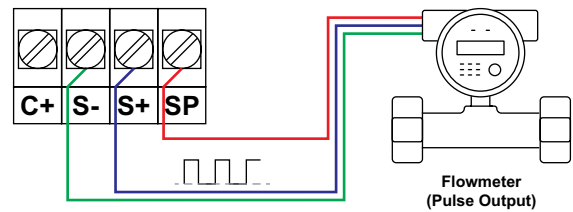

Flowmeter Powered by Internal Sensor Power (5 V @ 5 mA)

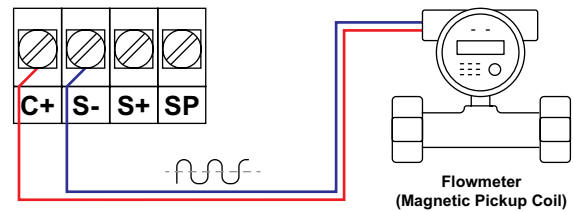

Self-Powered Magnetic Pickup Flowmeter (Coil)

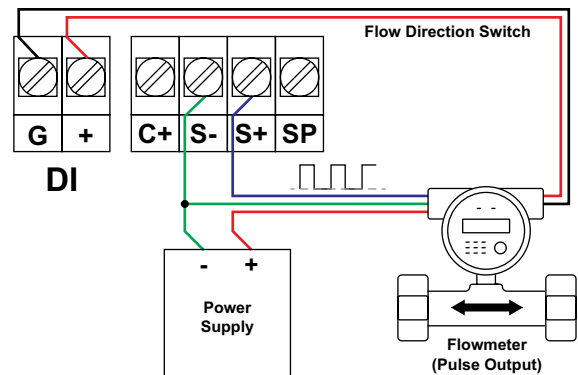

Bi-Directional Flowmeter Connections

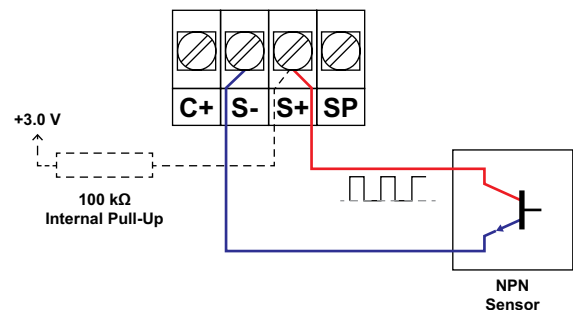

NPN Open Collector Input

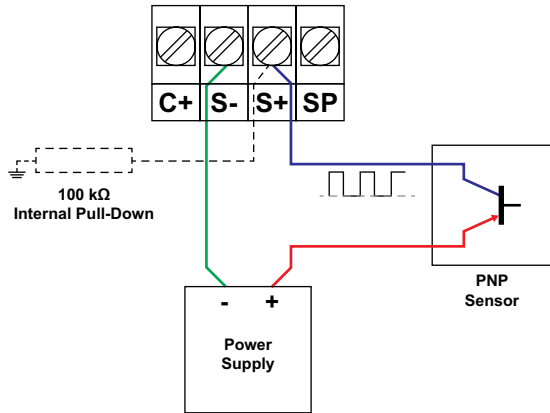

PNP Sensor with External Power

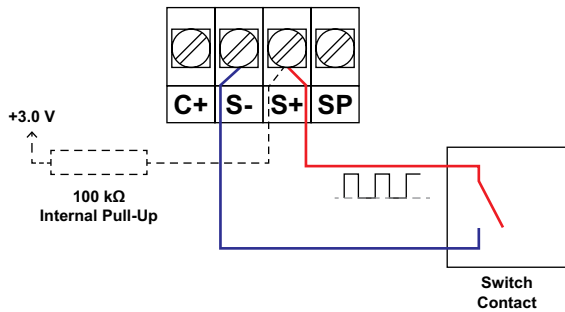

Switch Contact Input (Reed)

DC Power Connections

Models with battery power may optionally be connected to DC power and the battery will function as backup power when DC is lost. The same power supply may be used to power other circuits including a PNP-type sensor, however, to maintain input isolation, a separate power supply must be used to power the isolated 4-20 mA transmitter output.

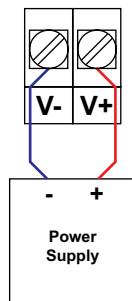

Digital Input Connections

A digital input is standard on the meter. This digital input is connected with a normally open contact across G and +, or with an active low signal applied to G and +.

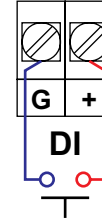

RS-485 Serial Connections

The RS-485 three-wire serial connection is standard. The cabling used for an RS-485 serial communications network should always be a high-quality cable such as Belden 8162 or Alpha 6203C. Signal ground is always recommended.

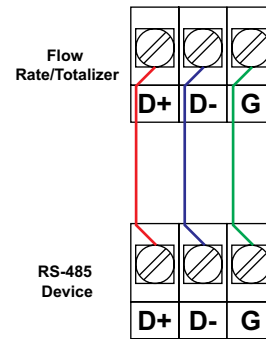

RS-485 2-Wire & Ground Serial Connections

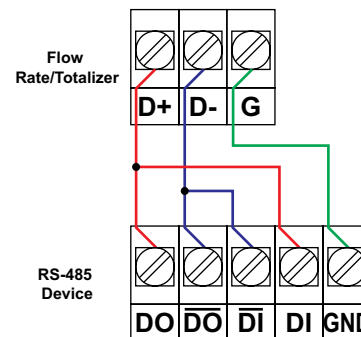

RS-485 4-Wire & Ground Serial Connections

IMPORTANT

- To connect the meter to the MeterView XL software using the RS-485 Modbus connection use a PDA8485 USB to RS-485 converter.

4-20 mA Output Connections

Connections for the 4-20 mA transmitter output are made to the connector terminals labeled mA OUT. The 4-20 mA output must be powered from an external power supply.

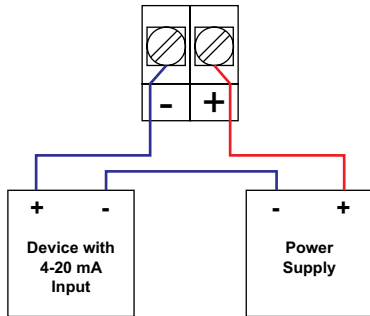

Solid-State Relay Connections

Relay connections are made to two-terminal connectors. Each relay's C terminal is common only to the normally open (NO) contact of the corresponding relay.

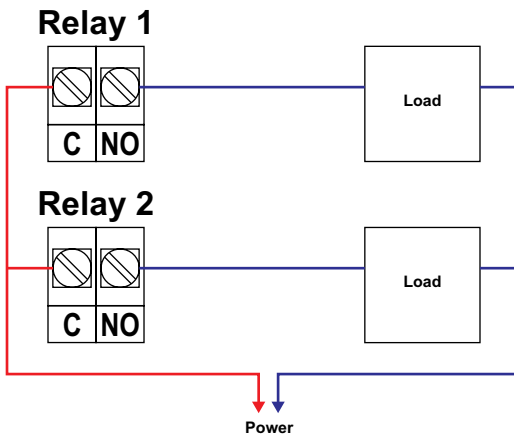

Open Collector Outputs

Open collector output 1 and 2 connections are made to terminals labeled O1+ and O1-, and O2+ and O2-. Connect the alarm or pulse input device as shown below.

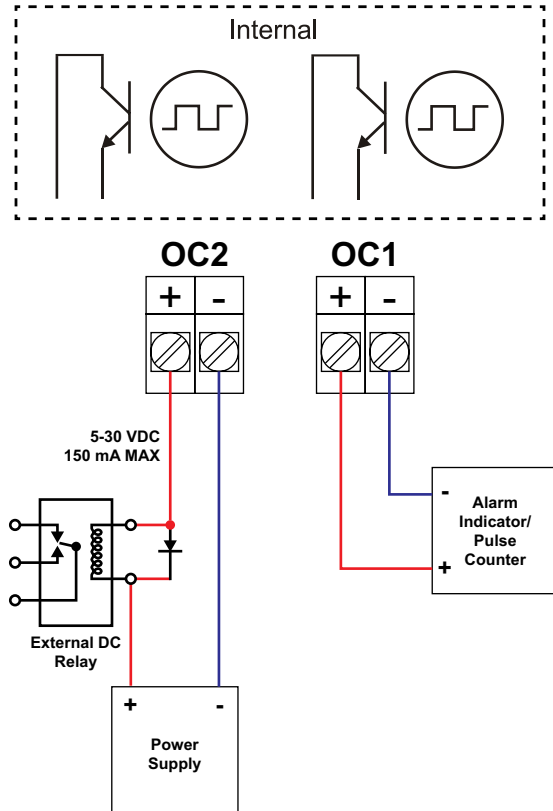

SPECIFICATIONS

Except where noted all specifications apply to operation at +25°C.

Display

Display	Dual-line LCD with backlight. Both lines alphanumeric. Top: 0.7" (17.8 mm) 5 digits, 12-segment Bottom: 0.4" (10.2 mm) 8 characters, 14-segment Display may be programmed to turn red and flash a user-defined message on alarm condition.
LCD Sleep	Never, 1, 2, 5, 10, 20, 60 min Default: 10 min when battery powered; press any key for 2 sec to wake up the display. All inputs and outputs continue working.
Turn Meter Off/On	Press & hold the Menu key for 5 sec and follow the on-screen instructions. This feature helps extend battery life.
Top Display	5 digits (-9999 to 99999) or 5 characters (all capital & most lower-case letters)
Bottom Display	8 digits (-9,999,999 to 99,999,999; separated by commas) or 8 characters (all capital & most lower-case letters)
Backlight	Normal: white LED (enabled by default) Alarm: red LED (default) DC powered: steady on Battery powered: momentary (default: 10 sec) Output loop powered: varying intensity based on 4-20 mA output current
Bargraph	20 segments (100% label at top fixed) Assignable to rate, total, or off Scale: 0 to 100%
Display Assignment	Top & bottom displays can be assigned to rate, total, grand total, etc. See instruction manual for a complete list of assignable parameters.
Decimal Point	Up to four decimal places on top display and up to seven decimal places on bottom display
Commas	Commas to indicate 1000s (e.g. 88,987,628) on bottom display only
Alarm Indication	Programmable: red backlight, flashing display, alarm symbol ▲, bargraph segment flashes on alarm.
Custom Alarm Messages	Programmable for each relay/open collector: 8 characters maximum; displayed every 10 sec for 1 sec on bottom display. May be turned off.
Display Update Rate	Ambient > -10°C: 1 Update/Second Ambient = -20°C: 1 Update/2 Seconds From -20°C to -40°C the update rate slows down 1 second for every -2°C (e.g. at -24°C, 1 update/4 seconds). Below -40°C the display is not readable, but all the inputs and outputs work correctly.
Overrange	Top: 99999; Bottom: 99,999,999 (flashing)
Underrange	Top: -9999; Bottom: -9,999,999 (flashing)

General

Programming Method	Four CapTouch through-window buttons when cover is installed. The CapTouch buttons can be used with the cover removed. Free PC-based USB MeterView XL programming software.
Recalibration	Recommended at least every 12 months.

Environmental	Operating temperature range: -40 to 75°C (-40 to 167°F) Storage temperature range: ProtEX+: -55 to 85°C (-67 to 185°F) VantageView+: -40 to 85°C (-40 to 185°F) Installation temperature range: ProtEX+: -55 to 75°C (-67 to 167°F) (The display ceases to function, however inputs and outputs continue to operate) VantageView+: -40 to 75°C (-40 to 167°F) Relative humidity: 0 to 90% non-condensing Printed circuit boards are conformally coated
Max/Min Display	Max/min readings reached by the process are stored until reset by the user or until power to the meter is turned off.
Password	There are three separate passwords available that can be set independently of each other: Main, Total, and Grand Total. The Main password prevents access to the meter Programming Mode. Total and Grand Total passwords prevent resetting the total and grand total, respectively.
Non-Volatile Memory	Total and Grand Total values, and all programmed settings are stored in non-volatile memory for a minimum of ten years if power is lost.
Power Options	9-30 VDC Powered, 2 W max Battery Powered or 9-30 VDC Powered with Battery Backup Loop Output Powered (30 VDC max) Loop Output Powered with Battery Backup
Data Logging	Up to 2,032 records, recorded 4/day at specific times or at defined time intervals. Record contains date, time, rate, total, grand total, and open collectors & relays states.
Data Logging Modes	Continuous: The log data will wrap around, erasing the oldest records to save the new records. Banks of 16 records will be erased at a time. Stop when full: The log will stop recording when full and "LOG FULL" is displayed every 10 sec.
Connections	Removable screw terminal blocks Display terminals: accept 16 to 30 AWG wire Relay terminals: accept 12 to 26 AWG wire 4-20 mA output: accept 16 to 30 AWG wire
Tightening Torque	Display terminals: 2.5 lb-in (0.28 Nm) Relay terminals: 4.5 lb-in (0.5 Nm) 4-20 mA output terminals: 2.5 lb-in (0.28 Nm)
Overall Dimensions	ProtEX+: 5.25" x 5.65" x 4.80" (133 x 144 x 122 mm) (W x H x D) VantageView+: 5.25" x 5.65" x 4.18" (133 x 144 x 106 mm) (W x H x D)
Weight	ProtEX+: Aluminum: 5.1 lbs (2.3 kg); Stainless Steel: 9.4 lbs (4.3 kg) VantageView+: 1.9 lbs (0.9 kg)
Warranty	3 years parts and labor. See Warranty Information and Terms & Conditions on www.predig.com for complete details.

Battery

Battery life is dependent on how the meter is used. Backlight should only be used momentarily (10 sec on). Modbus should rarely be used on battery-power, it requires approximately 26 mA. See battery life tables below for details.

-IS Models (Options: P & R) 3xAA-Cell

Battery Type	3.6 V Lithium (Li-SOCl ₂), non-rechargeable P/N: PDABAT36AA3-PACK		
Battery Life	Operating Condition @ 2,000 Hz	Estimated Service Life	Suggested Replacement Interval
	Monitoring only, backlight off	35 months	30 months
	LCD sleep*, minimal CapTouch use, backlight off	57 months	50 months
	100 Hz open collector 1&2 outputs, minimal backlight use	24 months	20 months
Battery Replacement	Replace only with a Precision Digital original Model PDABAT36AA3-PACK		

-EX Models (Options: A & M) A-Cell

Battery Type	3.6 V Lithium (Li-SOCl ₂), non-rechargeable P/N: PDABAT36A1-PACK		
Battery Life	Operating Condition @ 2,000 Hz	Estimated Service Life	Suggested Replacement Interval
	Monitoring only, backlight off	17 months	15 months
	LCD sleep*, minimal CapTouch use, backlight off	28 months	25 months
	100 Hz open collector 1&2 outputs, minimal backlight use	12 months	10 months
Battery Replacement	Replace only with a Precision Digital original Model PDABAT36A1-PACK		

-EX Models (Options: B & N) C-Cell

Battery Type	3.6 V Lithium (Li-SOCl ₂), non-rechargeable P/N: PDABAT36C1-PACK		
Battery Life	Operating Condition @ 2,000 Hz	Estimated Service Life	Suggested Replacement Interval
	Monitoring only, backlight off	37 months	32 months
	LCD sleep*, minimal CapTouch use, backlight off	61 months	53 months
	100 Hz open collector 1&2 outputs, minimal backlight use	26 months	21 months
Battery Replacement	Replace only with a Precision Digital original Model PDABAT36C1-PACK		

-GP Models (Options: A & M) A-Cell

Battery Type	3.6 V Lithium (Li-SOCl ₂), non-rechargeable P/N: PDABAT36A1NA-PACK		
Battery Life	Operating Condition @ 2,000 Hz	Estimated Service Life	Suggested Replacement Interval
	Monitoring only, backlight off	17 months	15 months
	LCD sleep*, minimal CapTouch use, backlight off	28 months	25 months
	100 Hz open collector 1&2 outputs, minimal backlight use	12 months	10 months
Battery Replacement	Replace with a Precision Digital original Model PDABAT36A1NA-PACK Optional C-Cell battery replacement available Model PDABAT36C1NA-PACK		

-GP Models Optional C-Cell Battery Replacement

Battery Type	3.6 V Lithium (Li-SOCl ₂), non-rechargeable P/N: PDABAT36C1NA-PACK		
Battery Life	Operating Condition @ 2,000 Hz	Estimated Service Life	Suggested Replacement Interval
	Monitoring only, backlight off	37 months	32 months
	LCD sleep*, minimal CapTouch use, backlight off	61 months	53 months
	100 Hz open collector 1&2 outputs, minimal backlight use	26 months	21 months

Battery Life with Modbus Continuously On

3XAA-Cell	277 hours
A-Cell	138 hours
C-Cell	296 hours

*LCD sleep: Press any key to wake up the display. All input & outputs continue working in LCD Sleep mode.

Enclosure

Material	ProtEX+ -AL Models: ASTM A413 LM6 die-cast aluminum, copper-free, enamel coated ProtEX+ -SS Models: ASTM A743 CF8M investment-cast 316 stainless steel VantageView+ -PL Models: Polycarbonate plastic with UV stabilizer
Gasket	ProtEX+ Models: Fluoroelastomer VantageView+ Models: Buna-N
Rating	-AL/-SS: NEMA 4X, IP68 Explosion-proof -PL: NEMA 4X, IP66 plastic, UL 94V-0
Color	-AL: Blue; -SS: Silver; -PL: Grey
Window	-AL/-SS: Borosilicate glass -PL: Clear polycarbonate with UV stabilizer
Conduits	-AL/-SS: Three 3/4" NPT or M20 threaded conduit openings. Optionally, the bottom opening can be supplied with 1" NPT opening. See Ordering Info for details. -PL: Three 3/4" NPT threaded conduit openings
Conduit Stopping Plug	-AL/-SS: Sold separately -PL: Two 3/4" NPT plastic conduit plugs with 1.29" wrenching flats and a screwdriver slot are included
Flange	Built-in flange for wall and pipe mounting.
Tamper-Proof Seal	Cover may be secured with tamper-proof seal.
Instrument Tag Loop	Built-in loop for securing stainless steel tag
ATEX & IECEx (ProtEX+ enclosure only)	Flameproof Ⓜ II 2GD Ex db IIC Gb Ex tb IIIC Db IP66/IP68 Tamb: -55°C to +85°C Certificate No.: Sira 19ATEX1252U Certificate No.: IECEx SIR 19.0075U
CSA (ProtEX+ enclosure only)	Class I, Division 1, Groups A, B, C, D Class II, Division 1, Group E, F, G Class III Ex db IIC Gb Ex tb IIIC Db Class I, Zone 1, AEx db IIC Gb Zone 21, AEx tb IIIC Db IP66/IP68/TYPE 4X Tamb: -55°C to +85°C Certificate No.: 80011200
UL (ProtEX+ enclosure only)	Class I, Division 1, Groups A, B, C, D Class II, Division 1, Groups E, F, G Class III Class I, Zone 1, AEx db IIC Gb Zone 21, AEx tb IIIC Ex db IIC Gb Ex tb IIIC Db IP66/IP68/TYPE 4X Tamb: -55°C to +85°C Certificate Number: E518920

Note: The above approvals are for the enclosure only. See *Compliance Information* for approvals on the entire instrument.

Pulse Input

Pulse, Transistor, Contact Closure	Pulse or square wave: 0-5 V, 0-12 V, or 0-24 V; TTL; NPN or PNP Open collector: 100 kΩ pull-up to 2.8 V Switch contact: 100 kΩ pull-up to 2.8 V PNP transistor: 100 kΩ pull-down to ground Active input: 100 kΩ pull-up to 2.8 V NPN strong: 10 kΩ pull-up to 2.8 V (Do not use with battery power) Maximum Frequency: 100 kHz Minimum Pulse Width: 5 μs									
	<table border="1"> <thead> <tr> <th>Threshold Setting</th> <th>Low (V)</th> <th>High (V)</th> </tr> </thead> <tbody> <tr> <td>Active/NPN</td> <td>0.5</td> <td>1.8</td> </tr> <tr> <td>Active/NPN High</td> <td>2.8</td> <td>4.8</td> </tr> </tbody> </table>	Threshold Setting	Low (V)	High (V)	Active/NPN	0.5	1.8	Active/NPN High	2.8	4.8
Threshold Setting	Low (V)	High (V)								
Active/NPN	0.5	1.8								
Active/NPN High	2.8	4.8								
Magnetic Pickup Coil	Sensitivity: 10 mVp-p to 24 Vp-p Maximum Frequency: 40 kHz Note: 10 mVp-p @ 300 Hz max									
Sensor Power	5 VDC @ 5 mA Enabled in the Advanced – System menu									
Minimum Input Frequency	0.0001 Hz Minimum frequency is dependent on high gate setting (rate display)									
Input Impedance	Pulse input: Greater than 75 kΩ @ 1 kHz. Open collector/switch: 100 kΩ pull-up to 2.8 V									
Contact Debounce Filter	Programmable contact debounce filter. Input signal frequency speed selections: Disable: Greater than 100 kHz (no filter) Fast: 1,000 Hz Medium: 240 Hz Slow: 100 Hz									
Accuracy	Rate: ±0.02% of calibrated span ±1 count Total: Every input pulse is counted									
Temperature Drift	2 PPM/°C from -40 to 75°C ambient									
Function	K-Factor: 0.000001 to 9,999,999 Rate: Linear (2-32 points)									
Low-Flow / Cutoff	0.1 to 999,999 or disable. Point below at which the display always shows zero.									
HART Transparency	The 4-20 mA output does not interfere with existing HART communications.									

Batch Control

Methods	Automatic or Manual, count up or count down
Manual Batch Start	Pressing F1 function key starts the batch
Manual Batch Pause/Stop	Pressing F3 once pauses the batch, pressing it twice cancels the batch
Automatic Batching	The PD6938 can be used as an automatic batch controller where batches run continuously without operator input
Batching Relay Operation	Single or dual-relay batching with optional preclose for two-stage operation
Batch Preset	Set via F2 function key anywhere between 0.0001 to 99,999 based on batch total decimal point. If batch total is assigned to bottom, the preset can be up to 8 digits.
Batch Preclose	For two-stage batch application, a preclose value can be set to close the main flow line.
Automatic Batch Restart Delay	1 to 9,999 seconds. The batch will automatically restart after completion of the last batch.

Rate/Totalizer

Rate Display	Top display: -9999 to 99999; Bottom display: -9,999,999 to 99,999,999 (with commas)
Total & Grand Total Display	Top display: 0 to 99999; Bottom display: 0 to 99,999,999 (with commas)
13-Digit Total & Grand Total	Up to 9,999,999,999,999 using both lines with 13-digit total feature enabled.
Total Decimal Point	Up to four decimal places on top, up to seven decimal places on bottom. Total decimal point is independent of rate decimal point.
Totalizer	Calculates total based on input pulses and rate units to display total in engineering units. A custom factor must be programmed if using custom defined units.
Time Base	Seconds, Minutes, Hours, Days
Totalizer Rollover	Totalizer rolls over when display exceeds 99,999,999 (9,999,999,999,999 if 13-digit limit enabled). Relay status reflects display.
Total & Grand Total Reset	Via CapTouch button, external contact closure on digital input, automatic based on time of day, or MeterView XL.
Time of Day Total & Grand Total Reset	Four programmable reset times. The total and grand total can be set up to reset at a time of day every day or any day.
Previous Total & Grand Total	Total & grand total are saved prior to applying the reset command. The previous totals can be read via the F1 function key and the Modbus registers.
Total & Grand Total Reset Passwords	Total and grand total passwords may be entered to prevent resetting the total or grand total unless a password is entered.
Non-Resetable Grand Total	Grand total reset may be disabled through the meter interface. Grand total reset may be permanently disabled by selecting YES at the PERMLCK menu.
CAUTION	
<ul style="list-style-type: none"> Once the Grand Total has been programmed as “non-resetable” the feature cannot be disabled. 	
Non-Volatile Memory	Total and Grand Total values are stored in non-volatile memory for a minimum of ten years if power is lost.

Common Open Collector & Relay Specifications

Number	Two open collectors & two relays
High or Low Alarm	User programmable for high or low alarm
Alarm Deadband	0-100% FS, user programmable
Output Assignment	Alarm, Timer, Stopwatch, or Disable
Alarm Output Source	Assign to rate, total, grand total, or digital input
On & Off Time Delay	0 to 9,999 seconds
Fail-Safe Operation	Independent for each open collector and relay. Fail-safe on, the output is on under normal conditions. Fail-safe off, the output is on under alarm conditions.
Alarm Operation	Automatic, automatic with manual override, latching (manual reset anytime), latching with reset after cleared (manual reset only after alarm has cleared)
Alarm Indication	Programmable: loop-powered red backlight, flashing display, alarm symbol ▲, bargraph segment flashes on alarm.
Custom Alarm Messages	Programmable for each relay/open collector: 8 characters maximum; displayed every 10 sec for 1 sec on bottom display. May be turned off.
Alarm Acknowledge	CapTouch ACK button or external digital input resets output and screen indication.
Auto Initialization	When power is applied to the meter, open collectors and relays will reflect the state of the input to the meter.
Timer Output	One-shot or Continuous Off Time Delay: 1 sec to 99:59:59 (hrs:min:sec) On Time: 1 sec to 99:59:59 (hrs:min:sec)
Stopwatch	Output turns on when started and off when stopped.

Open Collector Outputs

Rating	Isolated open collector, sinking NPN 5-30 VDC @ 150 mA maximum
Output Assignment	Pulse, Alarm, Timer, Stopwatch on/off, or Disable
Pulse Output Source	Pulse output based on Rate, Total, Grand Total, or Test Frequency, Alarm, Timer, Total Reset, Stopwatch on/off, or Disable
Pulse Output Factor	0.000001 to 999,999.9
Pulse Width	0.25 ms @ 2 kHz; 500 ms @ 1 Hz; 50% duty cycle
Pulse Output Frequency	2,000 Hz maximum
Quadrature Pulse Output	Available for Output 2 (90° behind Output 1) 500 Hz maximum
Alarm Output Source	Assign to Rate, Total, Grand Total or Digital Input

Solid-State Relays

Rating	250 VAC/VDC @ 0.5 A resistive 38 VA; 250 VAC; 0.3 A pilot duty (inductive) 13 VA; 250 VDC; 0.3 A pilot duty (inductive)
Noise Suppression	Metal oxide varistors across outputs
Relay Assignment	Alarm, Sample, Timer, Batch, Stopwatch on/off, or Disable
Alarm Output Source	Assign to Rate, Total, Grand Total, or Digital Input
Relay Runtime	Meter will keep track of how long each relay has operated and display this information.
Relay Cycles	Meter will keep track of how many times the relays have cycled and display this information.

4-20 mA Transmitter Output (Passive)

Accuracy	±0.05% FS ±0.001mA
Output Source	Rate, total; reverse scaling allowed
Scaling Range	1.00 to 23.0 mA
Disable	High impedance state, less than 1 mA
Calibration	Factory calibrated: 0 to 100 GAL/Sec = 4.00 to 20.00 mA
Underrange	1.0 mA, 3.5 mA, or 3.8 mA, or Off; user selectable
Overrange	20.5 mA, 20.8 mA, 23.0 mA, or Off; user selectable
Isolation	500 V input-to-output
Temperature Drift	0.003 mA max from -40 to 75°C ambient
External Loop Power Supply	7.0 VDC to 30.0 VDC maximum
Output Loop Resistance	10-750 Ω @ 24 VDC; 10-1100 Ω @ 30 VDC (External resistance to maintain accuracy)

On-Board Digital Input

Function	Remote operation of front-panel buttons, acknowledge/reset relays, reset total, reset max/min values, start/stop batch, etc.
Contacts	2.1 VDC on contact. Connect normally open contacts across G and +
Logic Levels	Logic High: 2.4 to 30 VDC (max) Logic Low: 0 to 0.9 VDC

Serial Communications

Connection	RS-485, 3-wire; Isolation: 500 V. Non-isolated micro-USB.
Non-isolated micro-USB.	Modbus® RTU
Meter Address / Slave ID	1 - 247
Baud Rate	1,200; 2,400; 4,800; 9,600; 19,200; 38,400; or 57,600 bps.
Transmit Time Delay	Programmable between 0 and 199 ms
Parity/Stop Bit	Even, odd, or none with 1 or 2 stop bits
Byte-to-Byte Timeout	Max of 1.5 character times or 2.25 ms

Note: Refer to the ProtEX+ and VantageView+ PD6938 Modbus® Register Tables located at www.predig.com for details.

MeterView XL

Availability	Free download from www.predig.com/meterviewxl
System Requirements	Microsoft® Windows® 10 & 11
Communications	USB 2.0 (Standard USB A to Micro USB B) Cable provided
Configuration	Configure all parameters on the meter. Configure meters one at a time.
Configuration Files	Generate with or without meter connected; Save to file for later use.
USB Power Connection	The meter is powered by the USB connection during programming. There is no need to apply external power. Note: The meter will not be damaged if external power is applied to it during programming.

⚠ WARNING

- The meter should only be connected to a computer while it is located in a safe area.

Data Logging Report	The on-board data log can be downloaded via the USB or the RS-485 connection. Saved as “.csv” file format.
PC Data Logging	MeterView XL can be used to data log directly to a computer connected to the meter via the USB or the RS-485 connection. The user can select what to log and at what interval. <ul style="list-style-type: none"> • Rate • Total • Grand total • Open collector triggers • Relay triggers • Hold/Unhold outputs
Compatibility	Programs created for VantageView+ and ProtEX+ can be run on either meter. No other program sharing is permissible.

General Compliance Information

Electromagnetic Compatibility

EMC Emissions	<ul style="list-style-type: none"> CFR 47 FCC Part 15 Subpart B Class A emissions requirements (USA) ICES-003 Information Technology emissions requirements (Canada) AS/NZS CISPR 11 Group 1 Class A ISM emissions requirements (Australia/New Zealand) EN 55011 Group 1 Class A ISM emissions requirements (EU) EN 61000-6-4 Emissions requirements for Heavy Industrial Environments - Generic
EMC Emissions and Immunity	EN 61326-1 EMC requirements for Electrical equipment for measurement, control, and laboratory use – industrial use

Hazardous Area Approvals (ProtEX+ Only)

-HA Models (Dual Hazardous Approved)

CSA	<p>Explosion-proof for use in: Class I, Division 1, Groups B, C and D Dust-ignition proof for use in: Class II/III, Division 1, Groups E, F and G; T6 Flame-proof for use in: Class I, Zone 1, Ex d IIC T6 Ta = -55 to 75°C. Enclosure: Type 4X & IP66/IP68. Certificate number: CSA 11 2325749</p>
ATEX	<p>Intrinsically safe for use in: ⊕ II 1 G D Ex ia IIC T4 Ga Ex ia IIIC T200°C Da Ta = -55 to 75°C Enclosure: Type 4X & IP66/IP68 Install per Control Drawing DW2636 (contained within LIM6938-2) Certificate number: CML 18ATEX2089X</p> <p>Explosion-proof for use in: ⊕ II 2 G D Ex db IIC T6 Gb Ex tb IIIC T85°C Db IP68 Ta = -55 to 75°C Enclosure: Type 4X & IP66/IP68 Certificate number: Sira 10ATEX1116X</p>
IECEX	<p>Intrinsically safe for use in: Ex ia IIC T4 Ga Ex ia IIIC T200°C Da Ta = -55 to 75°C Enclosure: Type 4X & IP66/IP68 Install per Control Drawing DW2636 (contained within LIM6938-2) Certificate number: IECEX CML 18.0050X</p> <p>Explosion-proof for use in: Ex db IIC T6 Gb Ex tb IIIC T85°C Db IP68 Ta = -55 to 75°C Enclosure: Type 4X & IP66/IP68 Certificate number: IECEX SIR 10.0056X</p>

-IS Models (Intrinsically Safe Approved)

ATEX	<p>Intrinsically safe for use in: ⊕ II 1 G D Ex ia IIC T4 Ga Ex ia IIIC T200°C Da Ta = -55 to 75°C Enclosure: Type 4X & IP66/IP68 Install per Control Drawing DW2636 (contained within LIM6938-2) Certificate number: CML 18ATEX2089X</p>
IECEX	<p>Intrinsically safe for use in: Ex ia IIC T4 Ga Ex ia IIIC T200°C Da Ta = -55 to 75°C Enclosure: Type 4X & IP66/IP68 Install per Control Drawing DW2636 (contained within LIM6938-2) Certificate number: IECEX CML 18.0050X</p>

-EX Models (Explosion-Proof Approved)

CSA	<p>Explosion-proof for use in: Class I, Division 1, Groups B, C and D Dust-ignition proof for use in: Class II/III, Division 1, Groups E, F and G; T6 Flame-proof for use in: Class I, Zone 1, Ex d IIC T6 Ta = -55 to 75°C. Enclosure: Type 4X & IP66/IP68. Certificate number: CSA 11 2325749</p>
ATEX	<p>Explosion-proof for use in: ⊕ II 2 G D Ex db IIC T6 Gb Ex tb IIIC T85°C Db IP68 Ta = -55 to 75°C Enclosure: Type 4X & IP66/IP68 Certificate number: Sira 10ATEX1116X</p>
IECEX	<p>Explosion-proof for use in: Ex db IIC T6 Gb Ex tb IIIC T85°C Db IP68 Ta = -55 to 75°C Enclosure: Type 4X & IP66/IP68 Certificate number: IECEX SIR 10.0056X</p>

ORDERING INFORMATION

-GP Models (General Purpose)

Plastic Enclosure

DC Powered with A-Cell Battery Pack (Primary or Backup) ³	
Model	Description
PD6938-GP-PL-ANM	Pulse Input Field-Mount Flow Rate/ Totalizer, No Options
PD6938-GP-PL-A2M	Pulse Input Field-Mount Flow Rate/ Totalizer, Two Solid-State Relays
PD6938-GP-PL-A3M	Pulse Input Field-Mount Flow Rate/ Totalizer, 4-20 mA Analog Output
PD6938-GP-PL-A5M	Pulse Input Field-Mount Flow Rate/ Totalizer, Two Solid-State Relays & 4-20 mA Analog Output

Loop Output Powered ⁴	
Model	Description
PD6938-GP-PL-C3N	Pulse Input Field-Mount Flow Rate/ Totalizer, 4-20 mA Analog Output
PD6938-GP-PL-C5N	Pulse Input Field-Mount Flow Rate/ Totalizer, Two Solid-State Relays & 4-20 mA Analog Output

DC Powered ³	
Model	Description
PD6938-GP-PL-DNM	Pulse Input Field-Mount Flow Rate/ Totalizer, No Options
PD6938-GP-PL-D2M	Pulse Input Field-Mount Flow Rate/ Totalizer, Two Solid-State Relays
PD6938-GP-PL-D3M	Pulse Input Field-Mount Flow Rate/ Totalizer, 4-20 mA Analog Output
PD6938-GP-PL-D5M	Pulse Input Field-Mount Flow Rate/ Totalizer, Two Solid-State Relays & 4-20 mA Analog Output

Loop Output Powered with A-Cell Battery Pack (Backup) ⁴	
Model	Description
PD6938-GP-PL-M3N	Pulse Input Field-Mount Flow Rate/ Totalizer, 4-20 mA Analog Output
PD6938-GP-PL-M5N	Pulse Input Field-Mount Flow Rate/ Totalizer, Two Solid-State Relays & 4-20 mA Analog Output

Notes:

1. All VantageView+ models come with bargraph, two open collector outputs, and one digital input standard.
2. The meter comes standard with three 3/4" NPT conduit holes and two plastic conduit plugs.
3. Modbus is standard on all DC powered models.
4. Modbus is not available with loop-powered models.
5. General purpose battery powered meters are only available with an A-Cell battery pack. An optional C-Cell battery replacement is available and sold separately.

-HA Models (Dual Hazardous Approved)

Aluminum Enclosure

Loop Output Powered ⁶	
Model	Description
PD6938-HA-AL-C3N	Pulse Input Ex-Proof & I.S. Flow Rate/ Totalizer, 4-20 mA Analog Output
PD6938-HA-AL-C5N	Pulse Input Ex-Proof & I.S. Flow Rate/ Totalizer, Two Solid-State Relays & 4-20 mA Analog Output

DC Powered ⁵	
Model	Description
PD6938-HA-AL-DNM	Pulse Input Ex-Proof & I.S. Flow Rate/ Totalizer, No Options
PD6938-HA-AL-D2M	Pulse Input Ex-Proof & I.S. Flow Rate/ Totalizer, Two Solid-State Relays
PD6938-HA-AL-D3M	Pulse Input Ex-Proof & I.S. Flow Rate/ Totalizer, 4-20 mA Analog Output
PD6938-HA-AL-D5M	Pulse Input Ex-Proof & I.S. Flow Rate/ Totalizer, Two Solid-State Relays & 4-20 mA Analog Output

Stainless Steel Enclosure

Loop Output Powered ⁶	
Model	Description
PD6938-HA-SS-C3N	Pulse Input Ex-Proof & I.S. Flow Rate/ Totalizer, 4-20 mA Analog Output
PD6938-HA-SS-C5N	Pulse Input Ex-Proof & I.S. Flow Rate/ Totalizer, Two Solid-State Relays & 4-20 mA Analog Output

DC Powered ⁵	
Model	Description
PD6938-HA-SS-DNM	Pulse Input Ex-Proof & I.S. Flow Rate/ Totalizer, No Options
PD6938-HA-SS-D2M	Pulse Input Ex-Proof & I.S. Flow Rate/ Totalizer, Two Solid-State Relays
PD6938-HA-SS-D3M	Pulse Input Ex-Proof & I.S. Flow Rate/ Totalizer, 4-20 mA Analog Output
PD6938-HA-SS-D5M	Pulse Input Ex-Proof & I.S. Flow Rate/ Totalizer, Two Solid-State Relays & 4-20 mA Analog Output

Notes:

1. All ProtEX+ models come with bargraph, two open collector outputs, and one digital input standard.
2. The meter comes standard with three 3/4" NPT conduit holes.
3. To order different conduit holes, add the following at the end:
 - a. -21 for M20 conduit holes (e.g. PD6938-HA-AL-DNM-21)
 - b. -24 for one 1" bottom and two 3/4" NPT conduit holes (e.g. PD6938-HA-AL-DNM-24)
4. Meters with dual hazardous area approval are not available with battery power options.
5. Modbus is standard on all DC powered models.
6. Modbus is not available with loop-powered models.

-IS Models (Intrinsically Safe Approved)

Aluminum Enclosure

Loop Output Powered ⁶	
Model	Description
PD6938-IS-AL-C3N	Pulse Input Intrinsically Safe Flow Rate/ Totalizer, 4-20 mA Analog Output
PD6938-IS-AL-C5N	Pulse Input Intrinsically Safe Flow Rate/ Totalizer, Two Solid-State Relays & 4-20 mA Analog Output

DC Powered ⁵	
Model	Description
PD6938-IS-AL-DNM	Pulse Input Intrinsically Safe Flow Rate/ Totalizer, No Options
PD6938-IS-AL-D2M	Pulse Input Intrinsically Safe Flow Rate/ Totalizer, Two Solid-State Relays
PD6938-IS-AL-D3M	Pulse Input Intrinsically Safe Flow Rate/ Totalizer, 4-20 mA Analog Output
PD6938-IS-AL-D5M	Pulse Input Intrinsically Safe Flow Rate/ Totalizer, Two Solid-State Relays & 4-20 mA Analog Output

DC Powered with 3xAA Battery Pack (Primary or Backup) ⁵	
Model	Description
PD6938-IS-AL-PNM	Pulse Input Intrinsically Safe Flow Rate/ Totalizer, No Options
PD6938-IS-AL-P2M	Pulse Input Intrinsically Safe Flow Rate/ Totalizer, Two Solid-State Relays
PD6938-IS-AL-P3M	Pulse Input Intrinsically Safe Flow Rate/ Totalizer, 4-20 mA Analog Output
PD6938-IS-AL-P5M	Pulse Input Intrinsically Safe Flow Rate/ Totalizer, Two Solid-State Relays & 4-20 mA Analog Output

Loop Output Powered with 3xAA Battery Pack (Backup) ⁶	
Model	Description
PD6938-IS-AL-R3N	Pulse Input Intrinsically Safe Flow Rate/ Totalizer, 4-20 mA Analog Output
PD6938-IS-AL-R5N	Pulse Input Intrinsically Safe Flow Rate/ Totalizer, Two Solid-State Relays & 4-20 mA Analog Output

Stainless Steel Enclosure

Loop Output Powered ⁶	
Model	Description
PD6938-IS-SS-C3N	Pulse Input Intrinsically Safe Flow Rate/ Totalizer, 4-20 mA Analog Output
PD6938-IS-SS-C5N	Pulse Input Intrinsically Safe Flow Rate/ Totalizer, Two Solid-State Relays & 4-20 mA Analog Output

DC Powered ⁵	
Model	Description
PD6938-IS-SS-DNM	Pulse Input Intrinsically Safe Flow Rate/ Totalizer, No Options
PD6938-IS-SS-D2M	Pulse Input Intrinsically Safe Flow Rate/ Totalizer, Two Solid-State Relays
PD6938-IS-SS-D3M	Pulse Input Intrinsically Safe Flow Rate/ Totalizer, 4-20 mA Analog Output
PD6938-IS-SS-D5M	Pulse Input Intrinsically Safe Flow Rate/ Totalizer, Two Solid-State Relays & 4-20 mA Analog Output

DC Powered with 3xAA Battery Pack (Primary or Backup) ⁵	
Model	Description
PD6938-IS-SS-PNM	Pulse Input Intrinsically Safe Flow Rate/ Totalizer, No Options
PD6938-IS-SS-P2M	Pulse Input Intrinsically Safe Flow Rate/ Totalizer, Two Solid-State Relays
PD6938-IS-SS-P3M	Pulse Input Intrinsically Safe Flow Rate/ Totalizer, 4-20 mA Analog Output
PD6938-IS-SS-P5M	Pulse Input Intrinsically Safe Flow Rate/ Totalizer, Two Solid-State Relays & 4-20 mA Analog Output

Loop Output Powered with 3xAA Battery Pack (Backup) ⁶	
Model	Description
PD6938-IS-SS-R3N	Pulse Input Intrinsically Safe Flow Rate/ Totalizer, 4-20 mA Analog Output
PD6938-IS-SS-R5N	Pulse Input Intrinsically Safe Flow Rate/ Totalizer, Two Solid-State Relays & 4-20 mA Analog Output

Notes:

1. All ProtEX+ models come with bargraph, two open collector outputs, and one digital input standard.
2. The meter comes standard with three 3/4" NPT conduit holes.
3. To order different conduit holes, add the following at the end:
 - a. -21 for M20 conduit holes (e.g. PD6938-IS-AL-PNM-21)
 - b. -24 for one 1" bottom and two 3/4" NPT conduit holes (e.g. PD6938-IS-AL-PNM-24)
4. Battery powered meters with Intrinsically Safe approval are available only with 3xAA battery power option.
5. Modbus is standard on all DC powered models.
6. Modbus is not available with loop-powered models.

-EX Models (Explosion-Proof Approved)

Aluminum Enclosure

DC Powered with A-Cell Battery Pack (Primary or Backup) ⁵	
Model	Description
PD6938-EX-AL-ANM	Pulse Input Explosion-Proof Flow Rate/ Totalizer, No Options
PD6938-EX-AL-A2M	Pulse Input Explosion-Proof Flow Rate/ Totalizer, Two Solid-State Relays
PD6938-EX-AL-A3M	Pulse Input Explosion-Proof Flow Rate/ Totalizer, 4-20 mA Analog Output
PD6938-EX-AL-A5M	Pulse Input Explosion-Proof Flow Rate/ Totalizer, Two Solid-State Relays & 4-20 mA Analog Output

DC Powered with C-Cell Battery Pack (Primary or Backup) ⁵	
Model	Description
PD6938-EX-AL-BNM	Pulse Input Explosion-Proof Flow Rate/ Totalizer, No Options
PD6938-EX-AL-B2M	Pulse Input Explosion-Proof Flow Rate/ Totalizer, Two Solid-State Relays
PD6938-EX-AL-B3M	Pulse Input Explosion-Proof Flow Rate/ Totalizer, 4-20 mA Analog Output
PD6938-EX-AL-B5M	Pulse Input Explosion-Proof Flow Rate/ Totalizer, Two Solid-State Relays & 4-20 mA Analog Output

Loop Output Powered ⁶	
Model	Description
PD6938-EX-AL-C3N	Pulse Input Explosion-Proof Flow Rate/ Totalizer, 4-20 mA Analog Output
PD6938-EX-AL-C5N	Pulse Input Explosion-Proof Flow Rate/ Totalizer, Two Solid-State Relays & 4-20 mA Analog Output

DC Powered ⁵	
Model	Description
PD6938-EX-AL-DNM	Pulse Input Explosion-Proof Flow Rate/ Totalizer, No Options
PD6938-EX-AL-D2M	Pulse Input Explosion-Proof Flow Rate/ Totalizer, Two Solid-State Relays
PD6938-EX-AL-D3M	Pulse Input Explosion-Proof Flow Rate/ Totalizer, 4-20 mA Analog Output
PD6938-EX-AL-D5M	Pulse Input Explosion-Proof Flow Rate/ Totalizer, Two Solid-State Relays & 4-20 mA Analog Output

Loop Output Powered with A-Cell Battery Pack (Backup) ⁶	
Model	Description
PD6938-EX-AL-M3N	Pulse Input Explosion-Proof Flow Rate/ Totalizer, 4-20 mA Analog Output
PD6938-EX-AL-M5N	Pulse Input Explosion-Proof Flow Rate/ Totalizer, Two Solid-State Relays & 4-20 mA Analog Output

Loop Output Powered with C-Cell Battery Pack (Backup) ⁶	
Model	Description
PD6938-EX-AL-N3N	Pulse Input Explosion-Proof Flow Rate/ Totalizer, 4-20 mA Analog Output
PD6938-EX-AL-N5N	Pulse Input Explosion-Proof Flow Rate/ Totalizer, Two Solid-State Relays & 4-20 mA Analog Output

Stainless Steel Enclosure

DC Powered with A-Cell Battery Pack (Primary or Backup) ⁵	
Model	Description
PD6938-EX-SS-ANM	Pulse Input Explosion-Proof Flow Rate/ Totalizer, No Options
PD6938-EX-SS-A2M	Pulse Input Explosion-Proof Flow Rate/ Totalizer, Two Solid-State Relays
PD6938-EX-SS-A3M	Pulse Input Explosion-Proof Flow Rate/ Totalizer, 4-20 mA Analog Output
PD6938-EX-SS-A5M	Pulse Input Explosion-Proof Flow Rate/ Totalizer, Two Solid-State Relays & 4-20 mA Analog Output

DC Powered with C-Cell Battery Pack (Primary or Backup) ⁵	
Model	Description
PD6938-EX-SS-BNM	Pulse Input Explosion-Proof Flow Rate/ Totalizer, No Options
PD6938-EX-SS-B2M	Pulse Input Explosion-Proof Flow Rate/ Totalizer, Two Solid-State Relays
PD6938-EX-SS-B3M	Pulse Input Explosion-Proof Flow Rate/ Totalizer, 4-20 mA Analog Output
PD6938-EX-SS-B5M	Pulse Input Explosion-Proof Flow Rate/ Totalizer, Two Solid-State Relays & 4-20 mA Analog Output

Loop Output Powered ⁶	
Model	Description
PD6938-EX-SS-C3N	Pulse Input Explosion-Proof Flow Rate/ Totalizer, 4-20 mA Analog Output
PD6938-EX-SS-C5N	Pulse Input Explosion-Proof Flow Rate/ Totalizer, Two Solid-State Relays & 4-20 mA Analog Output

DC Powered ⁵	
Model	Description
PD6938-EX-SS-DNM	Pulse Input Explosion-Proof Flow Rate/ Totalizer, No Options
PD6938-EX-SS-D2M	Pulse Input Explosion-Proof Flow Rate/ Totalizer, Two Solid-State Relays
PD6938-EX-SS-D3M	Pulse Input Explosion-Proof Flow Rate/ Totalizer, 4-20 mA Analog Output
PD6938-EX-SS-D5M	Pulse Input Explosion-Proof Flow Rate/ Totalizer, Two Solid-State Relays & 4-20 mA Analog Output

Loop Output Powered with A-Cell Battery Pack (Backup) ⁶	
Model	Description
PD6938-EX-SS-M3N	Pulse Input Explosion-Proof Flow Rate/ Totalizer, 4-20 mA Analog Output
PD6938-EX-SS-M5N	Pulse Input Explosion-Proof Flow Rate/ Totalizer, Two Solid-State Relays & 4-20 mA Analog Output

Loop Output Powered with C-Cell Battery Pack (Backup) ⁶	
Model	Description
PD6938-EX-SS-N3N	Pulse Input Explosion-Proof Flow Rate/ Totalizer, 4-20 mA Analog Output
PD6938-EX-SS-N5N	Pulse Input Explosion-Proof Flow Rate/ Totalizer, Two Solid-State Relays & 4-20 mA Analog Output

Notes:

- All ProtEX+ models come with bargraph, two open collector outputs, and one digital input standard.
- The meter comes standard with three 3/4" NPT conduit holes.
- To order different conduit holes, add the following at the end:
 - 21 for M20 conduit holes (e.g. PD6938-IS-AL-PNM-21)
 - 24 for one 1" bottom and two 3/4" NPT conduit holes (e.g. PD6938-IS-AL-PNM-24)
- Battery powered meters with Explosion-Proof approval are available only with A and C Cell battery power options.
- Modbus is standard on all DC powered models.
- Modbus is not available with loop-powered models.

⚠ WARNING

Cancer and Reproductive Harm - www.P65Warnings.ca.gov

Disclaimer

The information contained in this document is subject to change without notice. Precision Digital Corporation makes no representations or warranties with respect to the contents hereof, and specifically disclaims any implied warranties of merchantability or fitness for a particular purpose.

©2023 Precision Digital Corporation. All rights reserved.

Accessories

General Accessories	
Model	Description
PDABAT36C1-PACK	3.6 V C-Cell Lithium Battery Pack
PDABAT36A1-PACK	3.6 V A-Cell Lithium Battery Pack
PDABAT36AA3-PACK	3.6 V 3xAA-Cell Lithium Battery Pack
PDABAT36A1NA-PACK	3.6 V A-Cell Lithium Battery Pack Unapproved
PDABAT36C1NA-PACK	3.6 V C-Cell Lithium Battery Pack Unapproved
PDAPLUG75	3/4" NPT 316 SS Conduit Plug with Approvals
PDAPLUG75P	3/4" NPT Plastic Conduit Plug
PDAPLUGM20	M20 316 SS Conduit Plug with Approvals
PDAREDUCER-75M-50F	M-3/4" NPT to F-1/2" NPT Reducer with Approvals
PDAREDUCER-75M-M20F	M-3/4" NPT to F-M20 Reducer with Approvals
PDA8485-I	USB to RS-485 Isolated Converter
PDA1002	6" DIN Rail Mounting Kit
PDA1024-01	24 VDC Power Supply for DIN Rail
PDA-MICROUSB	Micro-USB PC Programming Cable
PDA-SSTAG	Stainless Steel Tag

PDA2360 Series Control Stations	
Model	Description
PDA2360-E	Emergency Button
PDA2361-A	Ack Button
PDA2361-B	Blank Button
PDA2361-R	Reset Button
PDA2361-S	Stop Button
PDA2361-Q	Silence Button

Pipe Mounting Kits	
Model	Description
PDA6846	2" Zinc Plated Steel U-Bolt Kit with One U-Bolt
PDA6846-SS	2" Stainless Steel U-Bolt Kit with One U-Bolt

Note:

- Unless otherwise specified, the above accessories do not carry hazardous area approvals and are thus not suitable for location in hazardous areas.

LDS6938_B 09/23