

# ProtEX-MAX PD8-6262/PD8-6363 Dual-Input Rate/Totalizers

## Data Sheet



MeterView Pro

USB Install

- Fully Approved Explosion-Proof Dual Input Flow Rate/Totalizers
- Rate, Total, and Grand Total for Each Input
- Display Rate & Total at the Same Time
- Front Panel or Remote Total Reset
- Password Protection for Programming and Total Reset
- Total Stored in Non-Volatile Memory
- Dual-Line 6-Digit Display, 0.6" (15 mm) & 0.46" (12 mm)
- CapTouch Through-Glass Button Programming
- Display Mountable at 0°, 90°, 180°, & 270°
- Easy Field Scaling in Engineering Units with Applying an Input
- 4 Relays + Isolated 4-20 mA Output Option
- Free PC-Based, On-Board, MeterView Pro USB Programming Software
- SunBright Display Standard
- Operating Temperature Range: -55 to 65°C (-67 to 149°F)

- CSA Certified as Explosion-Proof / Dust-Ignition-Proof / Flame-Proof
- ATEX and IECEx Certified as Dust-Ignition-Proof / Flame-Proof
- Input Power Options: 85-265 VAC / 90-265 VDC or 12-24 VDC / 12-24 VAC
- Explosion-Proof, IP68, NEMA 4X Enclosure Available in Aluminum or Stainless Steel
- Modbus RTU Communication Protocol Standard
- 3-Year Warranty

#### ANALOG INPUTS

- 0-20 mA, 4-20 mA, 0-5 V, 1-5 V, and  $\pm 10$  V Inputs
- Dual Analog Inputs with Math Functions

#### PULSE INPUTS

- Pulse, Open Collector, NPN, PNP, TTL, Switch Contact, Sine Wave (Coil), Square Wave Inputs
- Gate Function for Display of Slow Pulse Rates

# FLUIDPRO

Dosing Systems

[www.fluidprodosingsystems.com.au](http://www.fluidprodosingsystems.com.au)

QLD 07 3071 7415 NSW 02 8069 2664 VIC 03 9021 6624

PRECISION DIGITAL CORPORATION

PRECISION  
DIGITAL

[www.predig.com](http://www.predig.com)

# The Complete **ProtEX<sup>TM</sup>** Series MAX



PD8-154  
**4-Point Alarm  
Annunciator**



PD8-6100  
**Strain Gauge Meter**



PD8-158  
**8-Point Alarm  
Annunciator**



PD8-6200  
**Analog Input  
Flow Rate/Totalizer**



PD8-765  
**Process &  
Temperature Meter**



PD8-6210  
**Analog Input Batch  
Controller**



PD8-6000  
**Process Meter**



PD8-6262  
**Analog Dual-Input  
Flow Rate/Totalizer**



PD8-6001  
**Feet & Inches  
Level Meter**



PD8-6300  
**Pulse Input  
Flow Rate/Totalizer**



PD8-6060  
**Dual-Input  
Process Meter**



PD8-6310  
**Pulse Input  
Batch Controller**



PD8-6080  
**Modbus<sup>®</sup> Scanner  
with Dual Analog Input**



PD8-6363  
**Pulse Dual-Input  
Flow Rate/Totalizer**



PD8-6081  
**Feet & Inches  
Modbus<sup>®</sup> Scanner**



PD8-7000  
**Temperature Meter**

Go to [PREDIG.COM](http://PREDIG.COM) for details on the entire ProtEX-MAX Series Meters



## TABLE OF CONTENTS

OVERVIEW . . . . .	4
KEY FEATURES. . . . .	5
OUTPUTS . . . . .	6
CAPTUCH THROUGH-GLASS BUTTONS . . . . .	7
QUICK & EASY SCALE & PROGRAMMING METHODS . . . . .	8
TOTALIZER CAPABILITIES . . . . .	9
APPLICATIONS . . . . .	9
DIGITAL COMMUNICATIONS. . . . .	10
PHYSICAL FEATURES . . . . .	11
ACCESSORIES . . . . .	13
DIMENSIONS . . . . .	15
CONNECTIONS . . . . .	15
SPECIFICATIONS . . . . .	16
ORDERING INFORMATION . . . . .	21

OVERVIEW



Connections

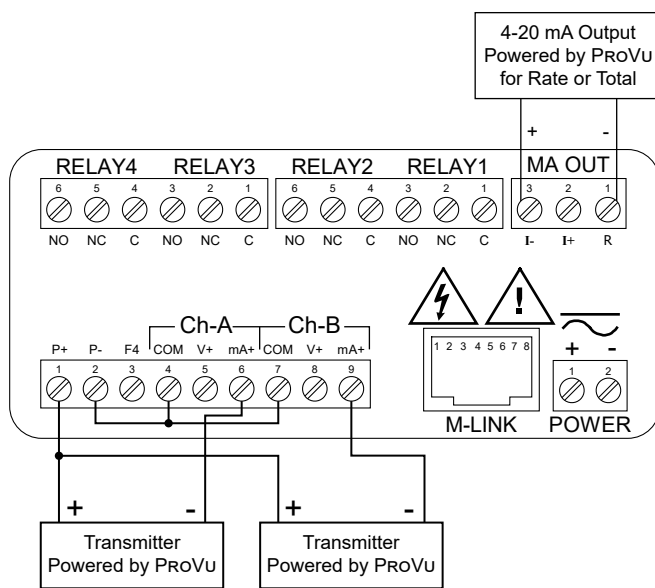

Connections for PD8-6262-6H7 & PD8-6262-7H7

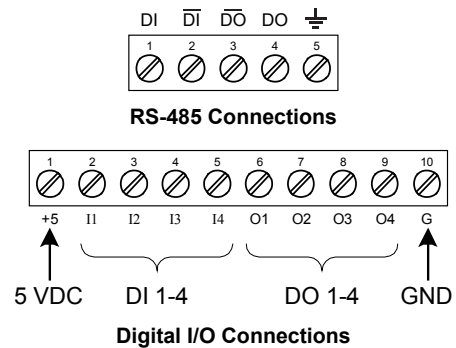

- Form C (SPDT) relays
- Two isolated supplies available even on 12/24 VDC input power models
- Removable terminal blocks
- 4 relays + isolated 4-20 mA output option
- Universal 85-265 VAC or 12/24 VDC input power
- Voltage or current inputs
- No jumpers needed for
- V/mA input selection
- Digital input (F4)

## KEY FEATURES

### Dual-Input Process Meter

The PD8-6262 has two process input channels (A & B) capable of accepting current (0-20, 4-20 mA) and voltage ( $\pm 10$ , 0-5, 1-5, 0-10 VDC). The PD8-6363 accepts two pulse (e.g.  $\pm 40$  mV to  $\pm 8$  V), square wave (0-5 V, 0-12 V, or 0-24 V), open collector, NPN, PNP, TTL or switch contact signals. Each input is programmed separately, with independent input type selection and scaling. These inputs may be displayed individually as part of the customizable dual-line display, or used with a wide range of math functions.

### Analog (PD8-6262)

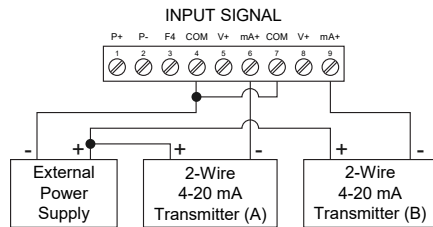

### Pulse (PD8-6363)

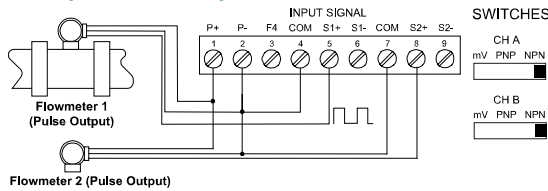

### Powerful Math Functions

The PD8-6262/PD8-6363 uses two rate input channels (A & B) with total and grand total for each in a variety of powerful math functions designed for a wide range of flow applications. Programmable adder (P) and factor (F) constants allow each formula to be customized as needed for a specific application. The math function (C) may be displayed with units, tags, channel A or B, rate, total or grand total, and in other useful combinations. See *math function chart under Specifications*.

### Totalizer Overflow Displays Total to 9 Digits

These flow rate/totalizers can display up to nine digits of total flow with the total overflow feature. In the diagrams below, the flow totalizer is displaying 532,831,470 by toggling between a display of "oF 532" and "831470". Notice the "oF" stands for overflow.

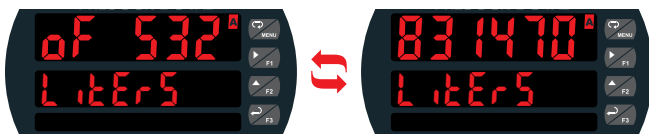

### Customizable Displays

The ProtEX-MAX has two red LED displays, a main display 0.60" (15 mm) high, and a second display 0.46" (12 mm) high. Each display is a full 6 digits (-99999 to 999999). The displays can be set up to read input channels (A or B), rate, total, or grand total, math function channel C, toggle between A & B, B & C, A & C, A & B & C, toggle between channels A, B, or C & units, the max/min of any of the channels, including the math channel (C), set points, or the Modbus input. This allows the display to be setup to display whatever variables are most valuable to the application. Here are just a few examples.



#### Math Function & Tag

The main display shows the math function result (C). The second display shows a custom label, in this case the math function used.



#### Math Function & Totals A & B

The main display shows the math function result (C). The second display alternates between totals A and B, with an indicator for each when being displayed.



#### Input Channels A & B Total

Both input channels are displayed, input A total on the main display and input B total on the second display. Indicators show A or B to label the display channel.

### Alternating Display

Certain display options alternate the display information. A single display can show input variable information as well as that channel's unit or tag. Input and math function channels, gross and net values, and select inputs and the math result may also alternate on a single display. Below are just a few of the options for setting up a single display to alternate information.



Lower Display Alternating Input Channels A & B Totals

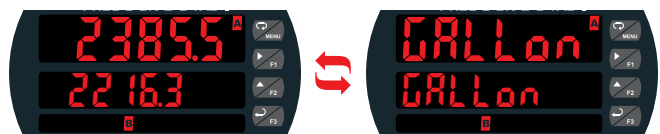

Both Displays Alternating Total and Unit

## OUTPUTS

### Analog Outputs

Each isolated analog retransmission signal can be configured to represent the channel A or B rate/process variable (PV), total, grand total, maximum (peak) value or minimum (valley) value; Channel C; math value; or the value for any of the eight relay set points, manual setting control, or Modbus input. While the output is nominally 4-20 mA, the signal will accurately accommodate under and over ranges from 1 to 23 mA.

### Relay Outputs

The ProtEX-MAX is available with four 3 A Form C relays (SPDT) with multiple power loss fail-safe options. Each relay may be assigned to input channel A or B, rate, total or grand total, or math result (C). Relays can be configured for proper protective action upon input loop break. Relay ON and OFF delay times are user adjustable. Up to eight front panel indicators show alarm and/or relay state. All relays can be configured for 0-100% deadband.

### Relay Operation/Configuration

There are powerful relay functions that can be configured in the ProtEX-MAX meter, including:

- Automatic reset only (non-latching)
- Automatic + manual reset at any time (non-latching)
- Latching (manual reset only)
- Latching with clear (manual reset only after alarm condition has cleared)
- Pump alternation control (automatic reset only)
- Sampling (activated for a user-specified time)
- User selectable fail-safe operation
- Relay action for loss (break) of 4-20 mA input signal
- Time delay (on and off), independent for each relay
- Manual control mode
- Interlock relay mode

### Interlock Relay(s)

This function allows a process to use one or more very low voltage input signals or simple switch contacts to control the state of one or more internal "interlock" relays. A violation (i.e. loss of input, open switch, or open circuit) forces one or more N/O interlock relay contacts to open. One input can be used in series with a number of interlock switches, or up to eight inputs can be required to force-on one (or more) internal interlock relays.

Please see Application Note AN-1008 on our website for more information. Requires PDA1044 Digital I/O module or use of on-board digital input F4.

### Sampling Function (PV Triggered Timed Relay)

The sampling function allows the operator to set a set point for a "sampling" relay. When the process (rate or total) reaches that set point, it will close that relay's contacts for a preset period of time (0.1 to 5999.9 seconds). An example of its use may be for wastewater sampling. When the wastewater total reaches a preset total interval (i.e. every 10,000 gallons), the relay contacts would close for a preset time, and by some means (light, horn, etc.) alert someone to take a sample, or provide the trigger to automatically take a sample of the wastewater. The utility of this function can, of course, be expanded beyond sampling and be used whenever a timed relay output closure is required when the rate or a total interval reaches a certain set point.

### Manual Output Control

Take control of any output with this feature. All relays can be forced ON or OFF, and the 4-20 mA output signal can be set to any value within its range. When the relays and 4-20 mA output are controlled manually, an LED labeled "M" is turned on and the associated Alarm LEDs (1-4) flash every 10 seconds indicating that the meter is in manual control mode.

## CAPTOUCH THROUGH-GLASS BUTTONS

The ProtEX-MAX is equipped with four capacitive sensors that operate as through-glass buttons so that they can be operated without removing the cover (and exposing the electronics) in a hazardous area or harsh environment. CapTouch buttons are designed to protect against false triggering and can be disabled for security by selecting DISABLE on the switch labeled NO-CONTACT BUTTONS located on the connector board.

### CapTouch Buttons

To actuate a button, press one finger to the window directly over the marked button area. When the cover is removed or replaced, the CapTouch buttons can be used after the meter completes a self-calibrating routine. The sensors are disabled when more than one button is pressed, and they will automatically re-enable after a few seconds. When the cover is removed, the four mechanical buttons located on the right of the faceplate are used.

The CapTouch Buttons are configured by default to duplicate the function of the front panel mechanical pushbuttons associated with the integrated meter.



**CAP  
TOUCH™**



Capacitive touch  
technology



More reliable &  
responsive



Operate meter  
without removing  
the cover

## QUICK & EASY SCALE & PROGRAMMING METHODS

The ProtEX-MAX can be programmed either via the front panel push buttons or free, PC-based MeterView Pro software. MeterView Pro is resident on the ProtEX-MAX and is accessed by a provided USB cable, so it is by far the easiest way to program the ProtEX-MAX. The ProtEX-MAX can be calibrated either by applying a known signal or scaled by entering a desired value with the front panel buttons or MeterView Pro software. Most customers will use the scaling method because it is simpler and does not require a calibrated signal source. Selecting the input to be current or voltage is done with the front panel buttons or MeterView Pro software. Once programming is completed it can be locked with a password.

### Free PC-Based MeterView Pro USB Programming Software & Cable

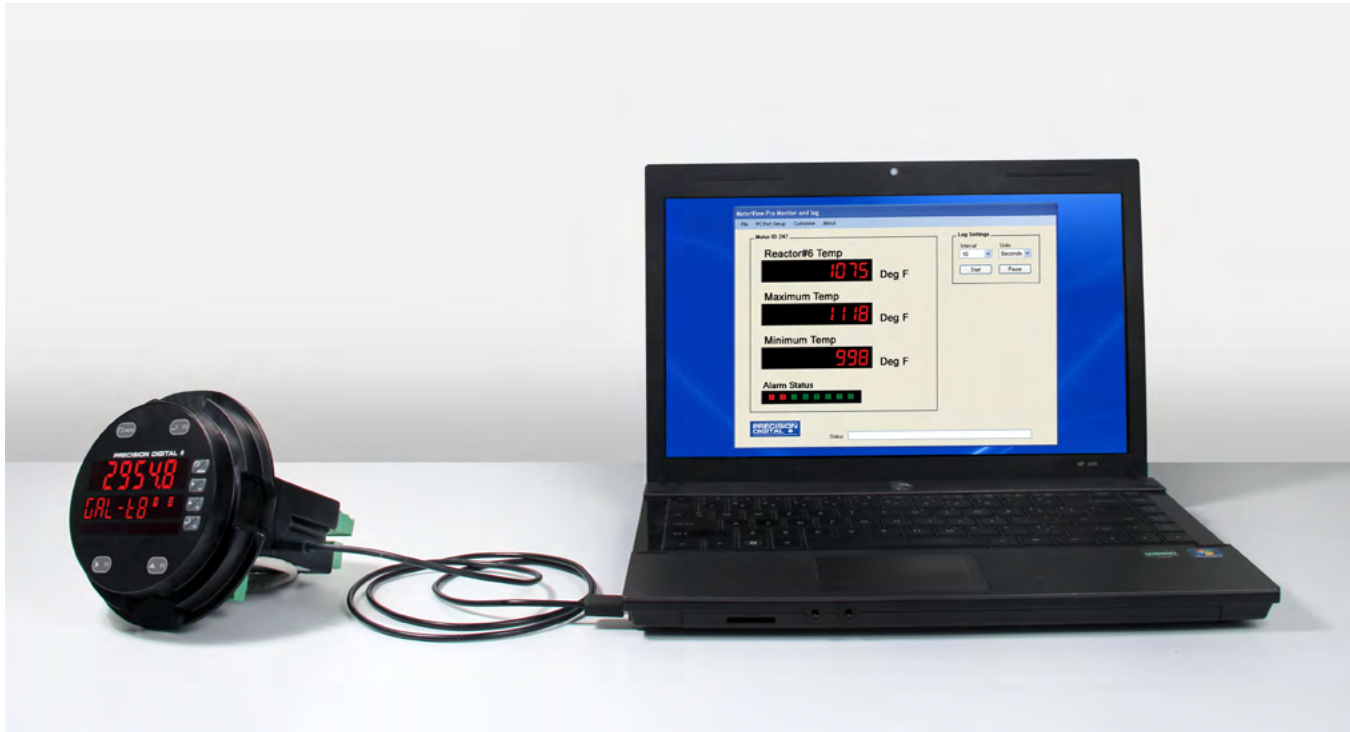

The ProtEX-MAX comes preloaded with free MeterView Pro programming software that connects and installs directly to your PC with a standard USB cable, also provided free with each instrument. This eliminates the need to insert CDs, install drivers, or download software from the internet. When you connect your ProtEX-MAX to your PC, MeterView Pro is downloaded to your PC, the software automatically selects the model you are programming, and you're ready to start programming immediately.

Further simplifying the programming process, the ProtEX-MAX can be powered from the USB port, so no need to apply external power while programming your meter. In addition to programming, the software will also allow you to monitor, and datalog a ProtEX-MAX using your PC. You can also generate and save programming files for later use.

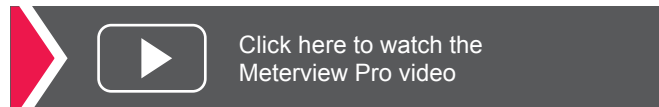



## TOTALIZER CAPABILITIES

ProtEX-MAX flow rate/totalizers can be programmed for a wide variety of totalizer applications. Each input channel has a total, grand total, or non-resettable grand total with a time base of seconds, minutes, hours or days. The user can program a totalizer conversion factor for each channel, a non-resettable grand total, password protection, and several total reset methods.

### Non-Resettable Grand Total

The user can set up the grand totals to be non-resettable by entering a specific password. Once this is done, the grand total can never be reset for either input channel.

### Totalizer Conversion Factors

The user can enter a totalizer conversion factor for each channel that allows the meter to display total in different units than the rate. For instance, a meter could display flow rate in gallons per minute and total in hundredths of acre-feet.

### Totalizer Password Protection

The totals and grand totals can be password protected so they can be reset only by authorized personnel.

### Remote Total Reset

An I/O expansion module or F4 digital input can be used to remotely reset the totals or grand totals. The reset switch is wired into the module or F4 input and the module is connected to the M-Link RJ45 connector at the back of the flow rate/totalizer.

### Total Alarms

The ProtEX-MAX's four internal and four external relays can be set up to alarm when the total of channel A or B, or channel C math based on the totals, reaches a user-defined set point. A variety of reset modes are available and the user can also program time delays and fail-safe operation.

## APPLICATIONS

### Differential Pressure Flow (PD8-6262)

The PD8-6262 can display flow rate and total by extracting the square root from the 4-20 mA signal from differential pressure transmitters. The user selectable low-flow cutoff feature gives a reading of zero when the flow rates drop below a user selectable value.

- Display Flow Rates and Totals
- User Selectable Low-Flow Cutoff
- Only 2 Calibration Points Required

### Open Channel Flow (PD8-6262)

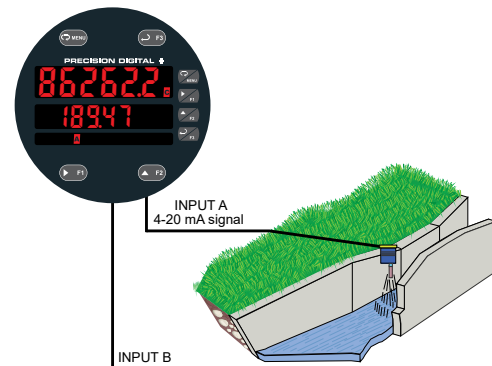

#### Weir Flow Calculated Using Exponential Signal Input Conditioning

The PD8-6262, in combination with ultrasonic level transmitters, makes for an economical way to measure and display open channel flow rates and totals in most weirs and flumes, and take periodic samples. All the user needs to do is enter the exponents for the weirs or flumes into the PD8-6262 and it will automatically raise the input signals to those powers. Sampling can be based on the total flow or the flow rate. Each channel's signal input conditioning is programmed independently.

### Convert Pulses to 4-20 mA (PD8-6363)

The PD8-6363 accepts pulse outputs from flowmeters and with the appropriate option installed, can convert the pulses to a 4-20 mA signal. The 4-20 mA signal can be programmed to correspond to either the flow rate or the total flow.

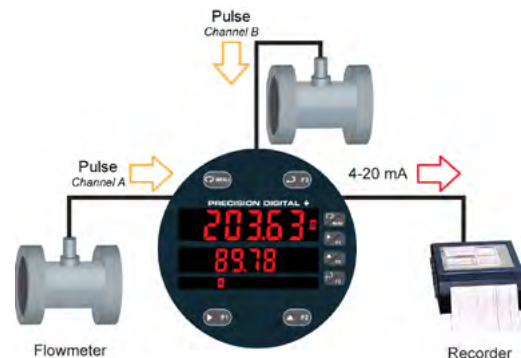

- Use K-Factor or Multi-Point Scaling
- ProtEX-MAX Powers the Flowmeters
- Up to 3 Analog Outputs

## DIGITAL COMMUNICATIONS

### Modbus RTU Serial Communications

With onboard RS-485 serial communication, the ProtEX-MAX can communicate with any Modbus *master* device using the popular Modbus communications protocol that is included in every ProtEX-MAX. In addition to the typical Modbus capabilities of reading PVs and writing set points, below are some examples of other things that can be done with the meter's Modbus communications:

- Start, pause, stop, or change preset values
- Send a 6-character message to the second display upon an event
- Remote user control (i.e. change set points, acknowledge alarms)
- Read rate, total, grand total, batch count, etc.

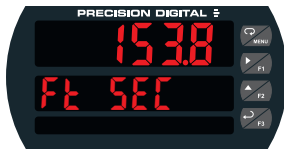

Modbus PV Input



Remote Message

 [Click here for more information on the PROVu's Modbus capabilities](#)

### Serial Adapters & Converters\*



**PDA7485-I**  
RS-232 to RS-422/485  
Isolated Converter



**PDA8485-I**  
USB to  
RS-422/485  
Isolated Converter

 For more info on serial converters click here.

\*All adapters and connectors supplied with appropriate cables.

### Integrated Digital I/O and Serial Communications



#### Digital I/O Connections

Four digital inputs and four digital outputs come standard with the ProtEX-MAX. External digital inputs can function similarly to the front panel function keys or digital input F4. They can be configured to trigger certain events (i.e. acknowledge/reset alarms, reset max and/or min values, disable/enable all output relays, and hold current relay states), or provide a direct menu access point. The inputs can be connected to a multi-button control station to provide the user with remote control of the four front panel push buttons.

Digital outputs can be used to remotely monitor the ProtEX-MAX's alarm relay output states, or the states of a variety of actions and functions executed by the meter.

**Note:** The onboard digital inputs (1-4) are configured at the factory to function identically to the front panel pushbuttons (Menu, F1, F2, & F3) in order to work with the CapTouch buttons. Changing the programming of the digital inputs will affect the function of the CapTouch buttons.

#### Serial Communications Connections



ProtEX-MAX meters come with an RS-485 connection for serial communications with other digital devices. The industry standard Modbus RTU protocol is included with every meter.

## PHYSICAL FEATURES

The ProtEX-MAX is designed for ease-of-use in safe and hazardous area applications, and is housed in a rugged NEMA 4X explosion-proof enclosure, available in either aluminum or stainless steel. The ProtEX-MAX can operate over a wide temperature range (-55 to 65°C / -67 to 149°F), includes removable screw terminal connectors, can have up to four relays and a 4-20 mA output, and features through-glass buttons for easy meter operation without the need to remove the cover. All of these features are backed by a 3-year warranty.

### Super-Bright LED Display

The ProtEX-MAX features a dual-line 6-digit display with super-bright LEDs, our brightest ever. These allow the display to be read in any lighting condition, even in direct sunlight.



### CapTouch Through-Glass Buttons

The ProtEX-MAX is equipped with four capacitive sensors that operate as through-glass buttons so that it can be programmed and operated without removing the cover (and exposing the electronics) in a hazardous area. These buttons can be disabled for security by selecting the DISABLE setting on the NO-CONTACT BUTTONS switch located on the back of the electronics module, inside the enclosure.

### Rugged Explosion-Proof Enclosure

The ProtEX-MAX is housed in a rugged NEMA 4X, 7, & 9, IP68 aluminum or stainless steel enclosure, designed to withstand harsh environments in safe and hazardous areas.



### Wide Viewing Angle

Customers can't always look at the display from straight on, so the window and display module have been optimized to provide a wide viewing angle of approximately  $\pm 40^\circ$ ; nearly twice that of the competition.



### Built-In Mounting Flanges

The ProtEX-MAX is equipped with two slotted flanges for wall mounting or NPS 1½" to 2½" or DN 40 to 65 mm pipe mounting.



### Flexible Mounting & Wiring

The ProtEX-MAX features four ¾" NPT threaded conduit openings so that wiring can be routed to the most convenient conduit connection(s).



## Rotatable Display

The ProtEX-MAX rotatable display, along with four available conduit connections, provide for numerous installation options. The display can be rotated in 90° increments. Rotate it 90° for horizontal mounting.



Vertical Mounting



Horizontal Mounting

## Perfect & Secure Fit Every Time

The internal cast rails ensure the ProtEX-MAX assembles together perfectly, quickly and securely; and everything lines up for optimal viewing every time. There are no standoffs to worry about breaking or getting out of alignment. The display module snaps into the built-in rails on the enclosure making assembly a snap, while pressing the display as close to the glass as possible to improve wide angle viewing. No tools are needed to install or remove it.

## PDA-SSTAG Stainless Steel Tags

PDA-SSTAG is a laser etched stainless steel tag accessory for any Precision Digital meter. The tag features custom text for equipment identification, instruction, or whatever else is needed in your facility. Each tag comes with a stainless steel wire and lead seal for easy mounting wherever you need it.



## Removable Screw Terminal Connectors

Industrial applications require screw terminal connections for easy field wiring and the ProtEX-MAX goes one step further in convenience by also making them removable.

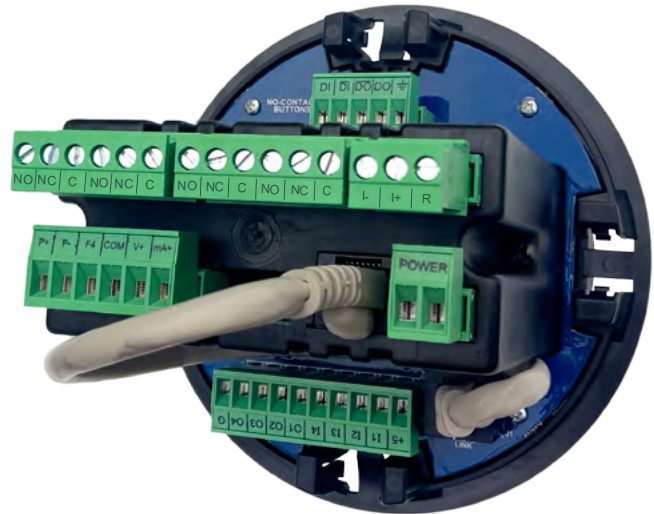

The above photograph is representative of the back of the PD8-6262 and PD8-6363 in every regard except for the signal input connector. See page 15 for actual input signal connections.

## USB Port MeterView Pro



## Hazardous Area Certification

The ProtEX-MAX is certified by CSA as Explosion-Proof / Dust-Ignition-Proof / Flame-Proof and is approved by ATEX and IECEx as Dust-Ignition-Proof / Flame-Proof.

## Wide Operating Temperature Range

The ProtEX-MAX can operate from -55 to 65°C (-67 to 149°F) meaning it can be installed in a wide variety of indoor and outdoor industrial applications.

**ACCESSORIES**

**PD9501 Multi-Function Calibrator**



This PD9501 Multi-Function Calibrator has a variety of signal measurement and output functions, including voltage, current, thermocouple, and RTD.

Model	Description
<a href="#">PD9501</a>	Multi-Function Calibrator

**PD9502 Low-Cost Signal Generator**



The PD9502 is a low-cost, compact, simple to use 4-20 mA or 0-10 VDC signal generator. It can easily be set for 0-20 mA, 4-20 mA, 0-10 V or 2-10 V ranges. Signal adjustment is made with a one-turn knob. A 15-27 VDC wall plug is provided with the instrument. Optional USB power bank is available.

Model	Description
<a href="#">PD9502</a>	Low-Cost Signal Generator

**⚠ WARNING**

- These accessories do not carry hazardous area approvals and are thus not suitable for location in hazardous areas. The use of additional protective devices may allow them to be installed in a safe area and connected to a device in a hazardous area. User should consult a professional engineer to determine suitability of these products for their specific application.

# Complete Product Line of Displays and Controllers IN ALL SHAPES, SIZES & LOCATIONS



Big, Bright Displays For Indoor or Outdoor in Bright Sunlight



Large Dual-Line 6-Digit Display



24 VDC Transmitter Power Supply



MeterView® Pro USB Programming Software



Universal 85-265 VAC or 12-24 VDC Input Power Options



4-20 mA, 0-10 V, Thermocouple, RTD, Strain Gauge, High Voltage, & Modbus Inputs



Up To Four 3 A Form C Relays (SPDT)



SP Ex IECEx CE

## EXPLOSION-PROOF ProtEX-MAX Series

- NEMA 4X, IP68 Rated Enclosure
- CapTouch Through-Glass Buttons
- Operating Temperature of -55 to 65°C
- Worldwide Approvals

## LARGE DISPLAYS Helios Series

- 1.8" Digits Readable From 100 Feet
- NEMA 4X, IP65 Rated Enclosure
- Operating Temperature of -40 to 65°C
- Now UL and C-UL Approved!

UL CE

## PANEL METERS ProVu Series

- NEMA 4X, IP65 Rated Front
- Programmable Function Keys
- UL, C-UL, and CE Approvals
- 1/8 DIN Size

Go to [PREDIG.COM](http://PREDIG.COM) for details on ProVu, ProtEX-MAX and Helios Series Meters

**DIMENSIONS**

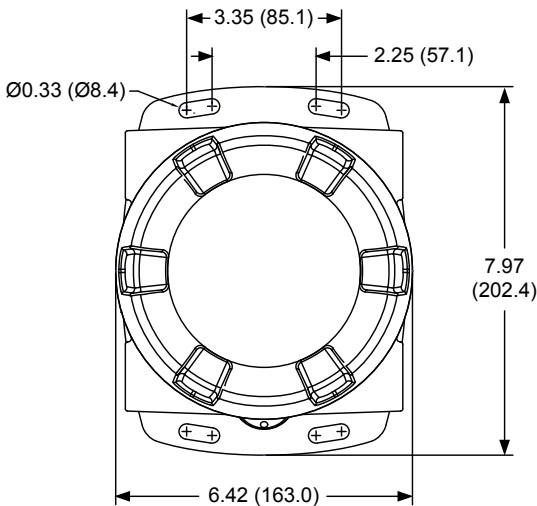
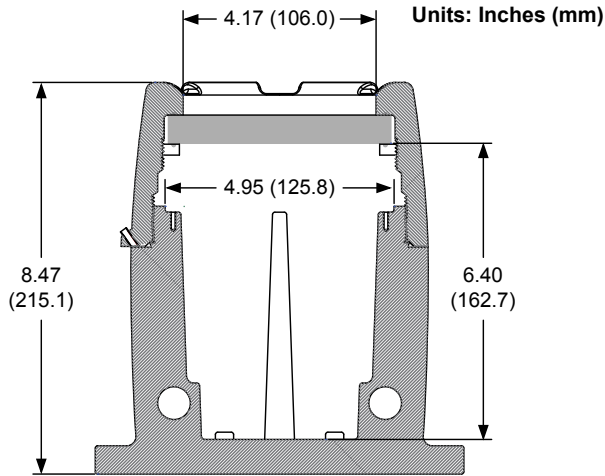

Download free 3-D CAD files of these instruments to simplify your drawings!  
[predig.com/documentation-cad](http://predig.com/documentation-cad)

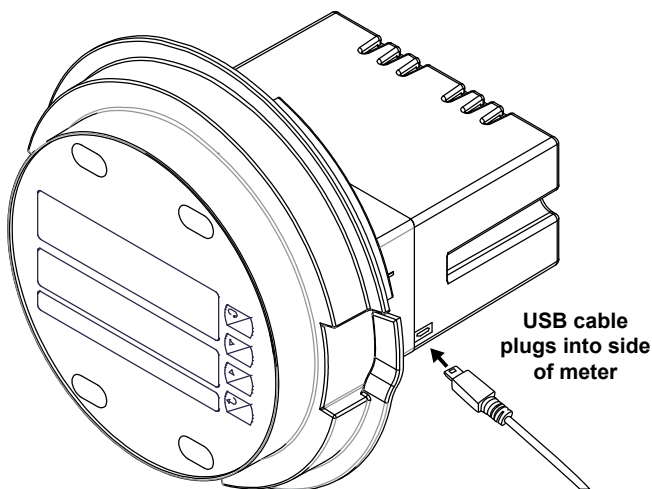

**CONNECTIONS**

**PD8-6262**

- Form C (SPDT) relays
- Two isolated power supplies available even on 12/24 VDC input power models
- Removable terminal blocks
- 4 relays + isolated 4-20 mA output option

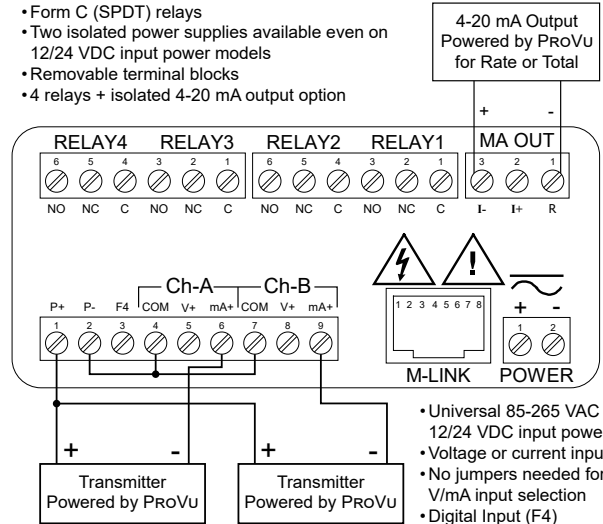

Connections for PD8-6262-6H7 & PD8-6262-7H7

**PD8-6363**

- Form C (SPDT) relays
- Two isolated power supplies available even on 12/24 VDC input power models
- Removable terminal blocks

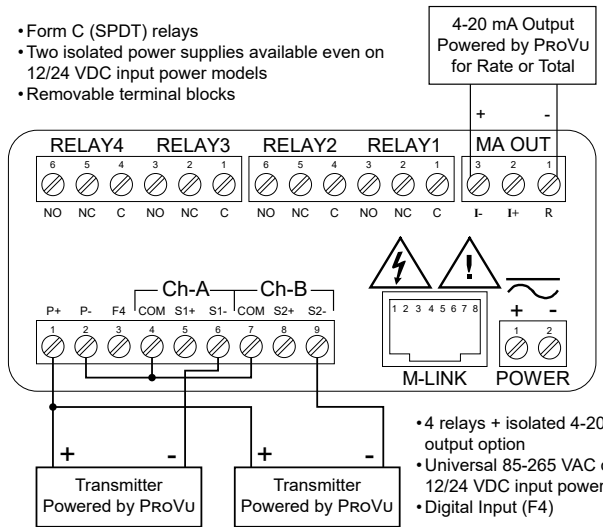

Connections for PD8-6363-6H7 & PD8-6363-7H7

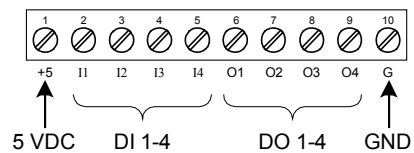

Digital I/O Connections

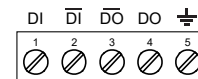

RS-485 Connections

## SPECIFICATIONS

Except where noted all specifications apply to operation at +25°C.

### General

**Display:** Upper display: 0.60" (15 mm) high. Lower display: 0.46" (12 mm) high. 6 digits each (-99999 to 999999), red LEDs with lead zero blanking.

**Display Intensity:** Eight user selectable intensity levels

**Display Update Rate:** PD8-6262: 5/second (200 ms) PD8-6363:

Rate: 10 per second; up to 1 per 100 seconds (and is a function of Low Gate setting); Total: 10 per second (fixed)

**Overrange:** Display flashes 999999

**Underrange:** Display flashes -99999

**Display Assignment:** The Upper and Lower displays may be assigned to show: One or more rate channels: Channel A (Ch-A), B (Ch-B), or C (Ch-C), Toggle between rate channels: Ch-A & Ch-B, Ch-A & Ch-C, Ch-B & Ch-C, and Ch-A, Ch-B, & Ch-C, Total or grand total: Ch-A or Ch-B, Rate and total or grand total: Ch-A, Ch-B, Relay set points, Max and/or min values: Ch-A, Ch-B, or Ch-C, Toggle between any rate channel & units, Toggle between any rate/math channel & units, Total and units: Ch-A or Ch-B, Toggle between totals: Ch-A & Ch-B; Ch-A, Ch-B, and sum of Ch-A and Ch-B, Modbus input. The lower display may also be set to show engineering units or be off, with no display.

**Programming Methods:** Four CapTouch through-glass buttons when cover is installed. Four internal pushbuttons when cover is removed.

**Max/Min Display:** Max/min readings reached by the process are stored until reset by the user or until power to the meter is cycled.

**Password:** Three programmable passwords restrict modification of programmed settings and two prevent resetting the totals.

**Noise Filter:** (PD8-6262) Programmable from 2 to 199 (0 will disable filter)

**Filter Bypass:** (PD8-6262) Programmable from 0.1 to 99.9% of calibrated span

**Non-Volatile Memory:** All programmed settings are stored in non-volatile memory for a minimum of ten years if power is lost.

**Recalibration:** All ranges are calibrated at the factory. Recalibration is recommended at least every 12 months.

**Power Options:** 85-265 VAC 50/60 Hz, 90-265 VDC, 20 W max, or optional model with 12-24 VDC ± 10%, 15 W max.

**Fuse:** Required external fuse: UL Recognized, 5 A max, slow blow; up to 6 meters may share one 5 A fuse.

**Isolated Transmitter Power Supply:** Terminals P+ & P-: 24 VDC ± 10%. internally selectable jumper for 24, 10, or 5 VDC supply.

All models transmitter supply rated @ 25 mA max.

**Normal Rejection Mode:** (PD8-6262) Greater than 60 dB at 50/60 Hz

**Isolation:** 4 kV input/output-to-power line. 500 V input-to-output or output-to-P+ supply.

**Overvoltage Category:** Installation Overvoltage Category II: Local level with smaller transient overvoltages than Installation Overvoltage Category III.

### Environmental:

T6 Class operating temperature range Ta = -55 to 60°C

T5 Class operating temperature range Ta = -55 to 65°C.

Storage temperature range: -55 to 85°C (-67 to 185°F).

Relative humidity: 0 to 90% non-condensing.

**Max Power Dissipation:** Maximum power dissipation limited to 15.1 W.

**Connections:** Removable screw terminal blocks accept 12 to 22 AWG wire, RJ45 for external relays, digital I/O, and serial communication adapters.

**Mounting:** Two slotted flanges for wall mounting or NPS 1/2" to 2 1/2" or DN 40 to 65 mm pipe mounting.

**Dimensions:** 6.42" x 7.97" x 8.47" (W x H x D) (163 mm x 202 mm x 215 mm)

**Weight:** Aluminum: 14.7 lbs (6.67 kg) Stainless Steel: 23.5 lbs (10.66 kg)

**Warranty:** 3 years parts & labor

**USB Connection:** Compatibility: USB 2.0 Standard, Compliant Connector Type: Micro-B receptacle

Cable: USB A Male to Micro-B Cable

Driver: Windows 98/SE, ME, 2000, Server 2003/2008, XP 32/64-

Bit, Vista 32/64-Bit, Windows 7 32/64-Bit, Windows 10 32/64-Bit

Power: USB Port

## Dual Input Functionality

**Analog Inputs:** (PD8-6262) Two inputs, each separately field selectable:

0-20, 4-20 mA, ±10 V (0-5, 1-5, 0-10 V), Modbus PV (Slave)

**Pulse Inputs:** (PD8-6363) Two, Field selectable: Pulse or square wave 0-5 V,

0-12 V, or 0-24 V @ 30 kHz; TTL; open collector 4.7 kΩ pull-up to 5 V @ 30 kHz; NPN or PNP transistor, switch contact 4.7 kΩ

pull-up to 5 V @ 40 Hz; Modbus PV (Slave)

**Channels:** Channel A, Channel B, Channel C (Math channel)

**Programmable Constants:** Constant P (Adder): -99.999 to 999.999, default: 0.000, Constant F (Factor): 0.001 to 999.999, default: 1.000

**Low Voltage Mag Pickup:** (PD8-6363) Sensitivity: 40 mVp-p to 8Vp-p

**Minimum Input Frequency:** (PD8-6363) 0.001 Hz Minimum frequency is dependent on high gate setting.

**Maximum Input Frequency:** (PD8-6363) 30,000 Hz (10,000 for low voltage mag pickup)

**Accuracy:** (PD8-6262) ±0.03% of calibrated span ±1 count, square root & programmable exponent accuracy range: 10-100% of calibrated span

(PD8-6363) ±0.03% of calibrated span ±1 count

### Math Functions:

Name	Function	Setting
Addition	(A+B+P)*F	5000
Difference	(A-B+P)*F	d f
Absolute diff.	((Abs(A-B))+P)*F	d f Rb5
Average	((A+B)/2+P)*F	Ru0
Multiplication	(A*B+P)*F	000000
Division	(A/B+P)*F	d 0 00E
Max of A or B	((AB-Hi)+P)*F	H 0-Rb
Min of A or B	((AB-Lo)+P)*F	L 0-Rb
Draw	(A/B-1)*F	d r R u
Weighted avg.	(B-A)*F+A	0 0 R u
Ratio	(A/B)*F	r R 0 0
Concentration	(A/(A+B))*F	[ 0 0 0 E 0
Total Addition	(tA+tB+P)*F	5000 t
G. Tot. Addition	(GtA+GtB+P)*F	5000 00E
Total Difference	(tA-tB+P)*F	d f t
G. Tot. Difference	(GtA-GthhhB+P)*F	d f 00E
Total Ratio	(tA/tB)*F	t r R 0 0
Total Percent	(tA/(tA+tB))*100	t P E

Note: The F constant can be any value from 0.001 to 999.999. If the value is less than 1, it will have the same effect as a divider. For example, the average could also be derived by using (A+B)/F, where F = 0.500.

### Sequence of Operations for Input Programming:

1. Select Input for A and B
2. Set up the rate, total, and grand total engineering units for channels A & B, and units for math channel C
3. Set up rate, total, and grand total decimal points for channels A & B, and decimal point for math channel C
4. Program channel A & B rate parameters
5. Program channel A & B total and reset parameters
6. Set up the big and little displays and display intensity
7. Select the transfer function for A & B (e.g. Linear)
8. Select Math function for Channel C
9. Program constants for Factor (F) and Adder (P)
10. Program cutoff values for A and B

**Temperature Drift:** 0.005% of calibrated span/°C max from 0 to 65°C ambient, 0.01% of calibrated span/°C max from -40 to 0°C ambient

(PD8-6363) Rate display is not affected by changes in temperature.

**Signal Input Conditioning:** (PD8-6262) Linear, square root, programmable exponent.

**Multi-Point Linearization:** 2 to 32 points for channel A and B

**Programmable Exponent:** (PD8-6262) 1.0001 to 2.9999

**Low-Flow Cutoff:** 0-999999 (0 disables cutoff function)

**Decimal Point:** Up to five decimal places or none: d d d d d d, d d d d d d, d d d d d d, d d d d d d, or d d d d d d.



**Calibration Range (PD8-6262):**

Input Range	Minimum Span
Range	Input 1 & Input 2
4-20 mA	0.15 mA
±10 V	0.10 V

An Error message will appear if input 1 and input 2 signals are too close together.

**Calibration Range (PD8-6363):** Input 1 signal may be set anywhere in the range of the meter; input 2 signal may be set anywhere above or below input 1 setting. Minimum input span between any two inputs is 10 Hz.

An error message will appear if the input span is too small.

**Calibration:** (PD8-6363) May be calibrated using K-factor, internal calibration, or by applying an external calibration signal.

**Input Impedance:** (PD8-6262) Voltage ranges: greater than 500 KΩ.

Current ranges: 50 - 100 Ω (depending on resettable fuse impedance).

**Input Overload:** (PD8-6262) Current input protected by resettable fuse,

30 VDC max. Fuse resets automatically after fault is removed.

**K-Factor:** (PD8-6363) Field programmable K-factor converts input pulses to rate in engineering units. May be programmed from 0.00001 to 999,999 pulses/unit.

**Filter:** (PD8-6363) Programmable contact de-bounce filter: 40 to 999 Hz

maximum input frequency allowed with low speed filter.

**Time Base:** (PD8-6363) Second, minute, hour, or day

**Gate:** (PD8-6363) Low gate: 0.1-99.9 seconds, High gate: 2.0-999.9 seconds

**F4 Digital Input Contacts:** 3.3 VDC on contact. Connect normally open contacts across F4 to COM.

**F4 Digital Input Logic Levels:** Logic High: 3 to 5 VDC, Logic Low: 0 to 1.25 VDC

**Dual Rate/Totalizer**

**Rate Display Indication:** 0 to 999999, lead zero blanking.

**Total Display & Total Overflow:** 0 to 999,999; automatic lead zero blanking. Up to 999,999,999 with total-overflow feature. "oF" is displayed to the left of total overflow.

**Total Decimal Point:** Up to five decimal places or none: dddddd,

dddddd, dddddd, dddddd, or dddddd. Total decimal point is independent of rate decimal point. Channel A and B decimal points programmed independently.

**Dual Totalizer:** Calculates total for channels A and B based on rate and field programmable multiplier to display total in engineering units. Time base must be selected according to the time units in which the rate is displayed. Channel A and B totalizer parameters programmed independently.

**Totalizer Rollover:** Totalizer rolls over when display exceeds 999,999,999. Relay status reflects the display value.

**Total Overflow Override:** Program total A or B total reset for automatic with 0.1 second delay and set point 1 for 999,999

**Totalizer Alarm Presets:** Up to eight, user selectable under setup menu. Any set point can be assigned to channel A or B total or grand total (or C) and may be programmed anywhere in the range of the meter for total alarm indication.

**Total & Grand Total Reset:** Via front panel button, external contact closure on digital inputs, automatically via user selectable preset value and

time delay, or through serial communications. Channel A and B total and grand total reset parameters programmed independently.

**Total Reset Password:** Total and grand total passwords may be entered to prevent resetting the total or grand total from the front panel.

**Non-Resettable Total:** The grand totals can be programmed as non-resettable totals by entering the password "050873". Both channels are set to non-resettable when this password is entered.

*Caution: Once the Grand Total has been programmed as "non-resettable" the feature cannot be disabled.*

**Programmable Delay on Release:** 0.1 and 999.9 seconds; applied to the first relay assigned to total or grand total. If the meter is programmed to reset total to zero automatically when the preset is reached, then a delay will occur before the total is reset.

## Relays

**Rating:** 4 SPDT (Form C) internal and/or 4 SPST (Form A) external; rated 3 A @ 30 VDC and 125/250 VAC resistive load; 1/14 HP ( $\approx$  50 W) @ 125/250 VAC for inductive loads

**Noise Suppression:** Noise suppression is recommended for each relay contact switching inductive loads.

**Relay Assignment:** Relays may be assigned to channel A or B rate, total, or grand total; channel C; or Modbus control.

**Deadband:** 0-100% of span, user programmable

**High or Low Alarm:** User may program any alarm for high or low trip point. Unused alarm LEDs and relays may be disabled (turned off).

**Relay Operation:** automatic (non-latching), latching (requires manual acknowledge), sampling (based on time), pump alternation control (2 to 8 relays), off (disable unused relays), and manual on/off control mode.

**Relay Reset:** User selectable via front panel buttons, digital inputs, or PC

1. Automatic reset only (non-latching), when input passes the reset point.
2. Automatic + manual reset at any time (non-latching).
3. Manual reset only, at any time (latching).
4. Manual reset only after alarm condition has cleared (latching).

*Note: Front panel button or digital input may be assigned to acknowledge relays programmed for manual reset.*

**Time Delay:** 0 to 999.9 seconds, on & off relay time delays.

Programmable and independent for each relay.

**Fail-Safe Operation:** Programmable and independent for each relay.

*Note: Relay coil is energized in non-alarm condition. In case of power failure, relay will go to alarm state.*

**Auto Initialization:** When power is applied to the meter, relays will reflect the state of the input to the meter.

## Isolated 4-20 mA Transmitter Output

**Output Source:** Input channels A or B, rate, total, or grand total; channel C; max or min for channel A or B; highest or lowest max or min of A and B; set points 1-8; Modbus input; or manual control mode.

**Scaling Range:** 1.000 to 23.000 mA for any display range

**Calibration:** Factory calibrated: 4.000 to 20.000 = 4-20 mA output

**Analog Output Programming:** 23.000 mA maximum for all parameters: Overrange, underrange, max, min, and break

**Accuracy:**  $\pm 0.1\%$  of span  $\pm 0.004$  mA

**Temperature Drift:**  $0.4 \mu\text{A}/^\circ\text{C}$  max from 0 to  $65^\circ\text{C}$  ambient,  $0.8 \mu\text{A}/^\circ\text{C}$  max from  $-40$  to  $0^\circ\text{C}$  ambient

*Note: Analog output drift is separate from input drift.*

**Isolated Transmitter Power Supply:** Terminals I+ & R: 24 VDC  $\pm 10\%$ . Isolated from the input at  $>500$  V. May be used to power the 4-20 mA output or other devices. All models @ 25 mA max.

**External Loop Power Supply:** 35 VDC maximum

**Output Loop Resistance:**

Power supply	Minimum	Maximum
24 VDC	10 $\Omega$	700 $\Omega$
35 VDC (external)	100 $\Omega$	1200 $\Omega$

## Serial Communications

**Protocol:** Modbus RTU

**Meter Address/Slave ID:** 1 - 247

**Baud Rate:** 300 - 19,200 bps

**Transmit Time Delay:** Programmable between 0 and 199 ms

**Data:** 8 bit (1 start bit, 1 or 2 stop bits)

**Parity:** Even, odd, or none with 1 or 2 stop bits

**Byte-to-Byte Timeout:** 0.01 - 2.54 seconds

**Turn Around Delay:** Less than 2 ms (fixed)

**Note:** Refer to the ProtEX-MAX Modbus Register Tables located at [www.predig.com](http://www.predig.com) for details.

## Enclosure

**Material:** AL Models: ASTM A413 LM6 die-cast aluminum, copper-free, enamel coated. SS Models: ASTM A743 CF8M investment-cast 316 stainless steel

**Gasket:** Fluoroelastomer

**Rating:** NEMA 4X, IP68 Explosion-proof

**Color:** AL: Blue. SS: Silver.

**Window:** Borosilicate glass

**Conduits:** Four 3/4" NPT threaded conduit openings

**Conduit Stopping Plugs:** Sold separately

**Flanges:** Two built-in flanges for wall and pipe mounting.

**Tamper-Proof Seal:** Cover may be secured with tamper-proof seal.

**Overall Dimensions:** 6.42" x 7.97" x 8.47" (W x H x D) (163 mm x 202 mm x 215 mm)

**Weight:** AL: 14.7 lbs (6.67 kg). SS: 23.5 lbs (10.66 kg).

**ATEX:** Flameproof protection

II 2 G D

Ex db IIC Gb

Ex tb IIIC Db

IP66/IP68

Tamb: -55°C to +85°C

Certificate Number: Sira 19ATEX1252U

**IECEX:** Flameproof and dust protection

Ex db IIC Gb

Ex tb IIIC Db

IP66/IP68

Tamb: -55°C to +85°C

Certificate Number: IECEX SIR 19.0075U

**CSA:** Class I, Division 1, Groups A, B, C, D

Class II, Division 1, Group E, F, G

Class III

Ex db IIC Gb

Ex tb IIIC Db

Class I, Zone 1, AEx db IIC Gb

Zone 21, AEx tb IIIC Db

IP66/IP68/TYPE 4X

Tamb: -55°C to +85°C

Certificate Number: CSA19.80011200U

**UL:** Class I, Division 1, Groups A, B, C, D

Class II, Division 1, Groups E, F, G

Class III

Class I, Zone 1, AEx db IIC Gb

Zone 21, AEx tb IIIC Db

Ex db IIC Gb

Ex tb IIIC Db

IP66/IP68/TYPE 4X

Tamb: -55°C to +85°C

Certificate Number: E518920

**Note:** The above approvals are for the enclosure only. See next page for approvals on the entire instrument.

## General Compliance Information

### Electromagnetic Compatibility

#### Emissions

EN 55022

Class A ITE emissions requirements

**Radiated Emissions:** Class A

**AC Mains Conducted Emissions:** Class A

#### Immunity

EN 61326-1

Measurement, control, and laboratory equipment

EN 61000-6-2

EMC heavy industrial generic immunity standard

#### RFI - Amplitude Modulated:

80 -1000 MHz 10 V/m 80% AM (1 kHz)

1.4 - 2.0 GHz 3 V/m 80% AM (1 kHz)

2.0 - 2.7 GHz 1 V/m 80% AM (1 kHz)

**Electrical Fast Transients:** ±2kV AC mains, ±1kV other

**Electrostatic Discharge:** ±4kV contact, ±8kV air

**RFI - Conducted:** 10V, 0.15-80 MHz, 1kHz 80% AM

**AC Surge:** ±2kV Common, ±1kV Differential

**Surge:** 1KV (CM)

#### Power-Frequency Magnetic Field:

30 A/m 70%V for 0.5 period

**Voltage Dips:** 40%V for 5 & 50 periods

70%V for 25 periods

Voltage Interruptions: <5%V for 250 periods

**Note:** Testing was conducted on meters with cable shields grounded at the point of entry representing installations designed to optimize EMC performance.

## Product Ratings and Approvals

**CSA:** Class I, Division 1, Groups B, C, D  
Class II, Division 1, Groups E, F, G  
Class III, Division 1, T5  
Class III, Division 1, T6 (Ta max = 60°C)  
Ex db IIC T5  
Ex db IIC T6 (Ta max = 60°C)  
Ex tb IIIC T90°C  
Ta = -55°C to +65°C  
Enclosure: Type 4X & IP66 / IP68  
CSA Certificate: CSA 12 2531731

**ATEX:** II 2 G D  
Ex db IIC T\* Gb  
Ex tb IIIC T90°C Db IP68  
Ta = -55°C to +\*°C  
\*T6 = -55°C to +60°C  
\*T5 = -55°C to +65°C  
Certificate Number: Sira 12ATEX1182X

**IECEX:** Ex db IIC T\* Gb  
Ex tb IIIC T90°C Db IP68  
Ta = -55°C to +\*°C  
\*T6 = -55°C to +60°C  
\*T5 = -55°C to +65°C  
Certificate Number: IECEX SIR 12.0073X

#### ATEX/IECEX Specific Conditions of Use:

- The equipment label and epoxy coating may generate an ignition-capable level of electrostatic charges under certain extreme conditions. The user should ensure that the equipment is not installed in a location where it may be subjected to external conditions (such as high-pressure steam) which might cause a build-up of electrostatic charges on non-conducting surfaces. Additionally, cleaning of the equipment should be done only with a damp cloth.
- Flameproof joints are not intended to be repaired.
- All entry closure devices shall be suitably certified as “Ex d”, “Ex t” and “IP66/68” as applicable. Suitable thread sealing compound (non-setting, non-insulating, non-corrosive, not solvent based, suitable for the ambient rating) must be used at the NPT conduit entries to achieve the IPx8 rating while maintaining the Ex protection concept.

#### Year of Construction

This information is contained within the serial number with the first four digits representing the year and month in the YYMM format.

#### For European Community

The ProtEX-MAX must be installed in accordance with the ATEX directive 2014/34/EU, the product manual, and the product certificate Sira 12ATEX1182X.

**ORDERING INFORMATION**

PD8-6262 Analog Inputs • Aluminum Enclosure		
85-265 VAC Model	12-24 VDC Model	Options Installed
PD8-6262-6H0	PD8-6262-7H0	None
PD8-6262-6H7	PD8-6262-7H7	4 Relays & 4-20 mA Output

PD8-6363 Pulse Inputs • Aluminum Enclosure		
85-265 VAC Model	12-24 VDC Model	Options Installed
PD8-6363-6H0	PD8-6363-7H0	None
PD8-6363-6H7	PD8-6363-7H7	4 Relays & 4-20 mA Output

PD8-6262 Analog Inputs • Stainless Steel Enclosure		
85-265 VAC Model	12-24 VDC Model	Options Installed
PD8-6262-6H0-SS	PD8-6262-7H0-SS	None
PD8-6262-6H7-SS	PD8-6262-7H7-SS	4 Relays & 4-20 mA Output

PD8-6363 Pulse Inputs • Stainless Steel Enclosure		
85-265 VAC Model	12-24 VDC Model	Options Installed
PD8-6363-6H0-SS	PD8-6363-7H0-SS	None
PD8-6363-6H7-SS	PD8-6363-7H7-SS	4 Relays & 4-20 mA Output

Note: 24 V flowmeter power supply standard on all models.

Accessories	
Model	Description
PDA-SSTAG	Stainless Steel Tag
PDAPLUG75	3/4" NPT 316 Stainless Steel Stopping Plug with Approvals
PDA7485-I	RS-232 to RS-422/485 Isolated Converter
PDA8485-I	USB to RS-422/485 Isolated Converter
PDA6848-SS	Pipe Mounting Kit Stainless Steel

**Your Local Distributor is:**



**WARNING**

Cancer and Reproductive Harm - [www.P65Warnings.ca.gov](http://www.P65Warnings.ca.gov)

**Disclaimer**

The information contained in this document is subject to change without notice. Precision Digital Corporation makes no representations or warranties with respect to the contents hereof, and specifically disclaims any implied warranties of merchantability or fitness for a particular purpose.

©2024 Precision Digital Corporation. All rights reserved.

LDS8-6262\_E 01/24